



SISTEMAS DE IMPLANTES IMPLANT SYSTEMS

www.gmidental.com



Implantes dentales de conexión interna hexagonal
Hexagonal internal connection dental implants

Made in Spain



Índice - Summary

CARACTERÍSTICAS GENERALES

- Tratamiento superficial / estudios
- Recomendaciones de uso
- Descripción del etiquetado

SISTEMAS DE IMPLANTES

- Implantes dentales **gmi frontier**
- Protocolo de inserción de implantes **gmi frontier**
- Gama de implantes **gmi frontier**
- Secuencias fresado para implantes **gmi frontier**
- Implantes dentales **gmi frontier PEAK**
- Protocolo de inserción de implantes **gmi frontier PEAK**
- Gama de implantes **gmi frontier PEAK**
- Secuencias fresado para implantes **gmi frontier PEAK**

ADITAMENTOS

- Pilares cicatrización **gmi frontier**
- Pilares fresables **gmi frontier**
- Pilares inclinados estéticos **gmi frontier**
- Pilares rectos **gmi frontier**
- Pilares provisionales **gmi frontier**
- Base titanio **gmi frontier**
- Pilares bola **gmi frontier**
- Pilares multi-estético **gmi frontier**
- Bases bioestéticas **gmi frontier**
- Réplicas **gmi frontier**
- Tomas de impresión **gmi frontier**
- Calcinables **gmi frontier**
- Bases CrCo **gmi frontier**
- Tornillos clínica y laboratorio **gmi frontier**
- Tornillos PME y BE **gmi frontier**
- Pares recomendados de apriete

KITS QUIRÚRGICOS GMI

- Kit quirúrgico **gmi frontier/avantgard**
- Kit cirugía guiada **gmi frontier**
- Kit quirúrgico **gmi PEAK**
- Kit cirugía guiada **gmi frontier PEAK**

ESPECIFICACIONES TÉCNICAS

KEY FEATURES

- Surface treatment / studies 4
- Recommendations of use 6
- Labelling description 7

IMPLANT SYSTEMS

- **gmi frontier** dental implants 8
- Insertion sequence for **gmi frontier** implants 9
- **gmi frontier** implants range 10
- Drilling sequences for **gmi frontier** implants 12
- **gmi frontier PEAK** dental implants 14
- Insertion sequence for **gmi frontier PEAK** implants 15
- **gmi frontier PEAK** implants range 16
- Drilling sequences for **gmi frontier PEAK** implants 17

ATTACHMENTS

- **gmi frontier** healing abutments 18
- **gmi frontier** millable-implant abutments 19
- **gmi frontier** esthetic angled abutments 20
- **gmi frontier** straight abutments 20
- **gmi frontier** temporary cylinders 21
- **gmi frontier** titanium base 22
- **gmi frontier** ball abutments 23
- **gmi frontier** multi-esthetic abutments 24
- **gmi frontier** bioesthetic bases 27
- **gmi frontier** replicas 29
- **gmi frontier** impression coping 30
- **gmi frontier** castables 31
- **gmi frontier** CrCo bases 32
- **gmi frontier** clinic and laboratory screws 32
- **gmi frontier** MEA and BE screws 33
- Recommended tightening torques 35

GMI SURGICAL KITS

- **gmi frontier/avantgard** surgical kit 37
- **gmi frontier** guided surgery kit 38
- **gmi PEAK** surgical kit 39
- **gmi frontier PEAK** guided surgery kit 40

TECHNICAL SPECIFICATIONS

41

Tratamiento superficial ADS®

ADS® surface treatment

Para favorecer la adherencia y el crecimiento de las células óseas se ha tratado la superficie exterior del implante con el exclusivo sistema ADS® (Advanced Double-Grip Surface) que combina un microbulado con corindón blanco con un ataque ácido para obtener una rugosidad no uniforme, que maximiza la superficie de contacto entre el implante y el hueso y por tanto, mejora la estabilidad y la unión entre ellos.

To promote the adhesion and growth of bone cells, the outer surface of the implant has been treated with the exclusive ADS® treatment (Advanced Double-Grip Surface) which combines a white corundum micro-bubble treatment and acid etching, for a non-smooth roughness that maximizes the contact surface between implant and bone and therefore improves stability and adhesion between them.

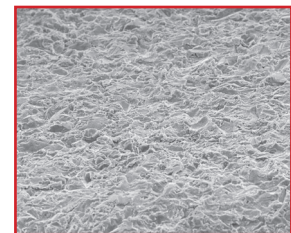
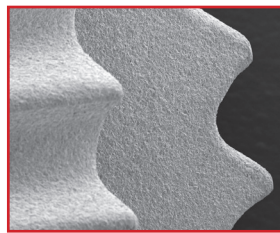
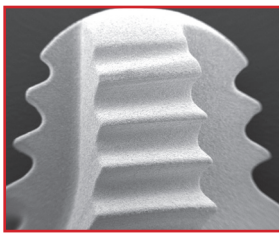

El tratamiento ADS® es el resultado de una serie de colaboraciones con institutos y universidades, así como estudios y ensayos propios que nos permiten controlar y validar la respuesta biológica óptima de la superficie del implante: se han efectuado tanto estudios químicos (estudios de dispersión rayos X para conocer la composición del implante y su superficie) como topográficos (estudios de rugosidad), así como estudios biológicos (estudios de respuesta in vivo en animales) y estudios clínicos.

The ADS® treatment is the result of a series of collaborations with institutes and universities, as well as our own research and tests, that allow us to monitor and validate the optimal biological response to the implant surface: chemical (X-ray scattering studies to find out the composition of the implant and its surface) and topography studies (roughness studies) have been carried out, as well as biological (in vivo response studies in animals) and clinical studies.

Estudios de composición

Composition studies

Los estudios efectuados por dispersión de rayos X demuestran que sobre la superficie del implante solo se encuentra titanio y oxígeno, que son los componentes básicos de la capa de óxido que se forma en el proceso de pasivado del implante, y que es la que le confiere la excelente resistencia a la corrosión.

X-ray scattering studies show that the surface of the implants is only made of titanium and oxygen, which are the basic components of the oxide layer that is formed in the implant passivation process and that gives it its excellent corrosion resistance.

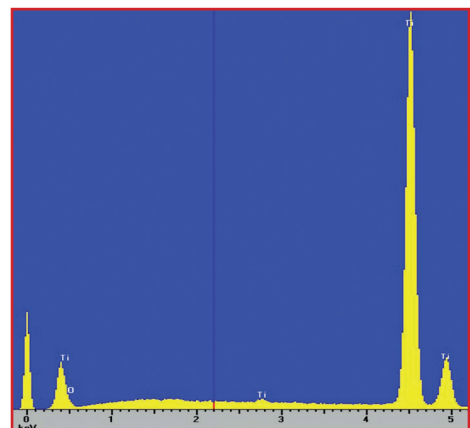

Estudios de la topografía de la superficie

Surface topography studies

Para controlar y conocer la topografía de la superficie del implante, se han efectuado estudios de rugosidad tanto con rugosímetros de contacto, como con técnicas SEM (Scanning Electron Microscope) y CLSM (Confocal Laser Scanning Microscope), permitiéndonos obtener y controlar los valores de la media aritmética de la rugosidad (Ra) dentro de los parámetros recomendados en las publicaciones internacionales.

In order to control and identify the topography of the implant surface, roughness studies were performed with profilometer, as well as with techniques such as SEM (Scanning Electron Microscope) and CLSM (Confocal Laser Scanning Microscope), allowing to obtain and control the mean roughness (Ra) values within the parameters recommended in international publications.

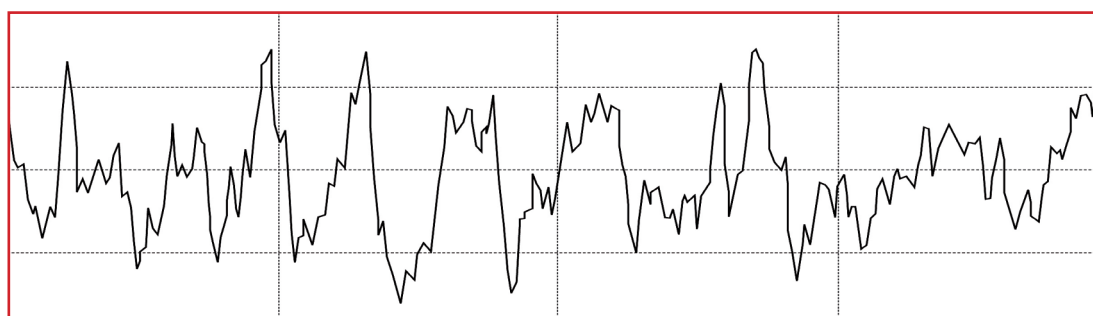

Perfil de rugosidad obtenido con HOMMEL-WERKE T1000 • Roughness profile obtained with HOMMEL-WERKE T1000.

Estudios de osteointegración

Osseointegration studies

Para conocer la respuesta biológica de los implantes **gmi**, se han efectuado estudios in vivo colocando los implantes en animales, dejándolos sin carga durante el proceso de cicatrización y efectuando un estudio histológico que demuestra la excelente respuesta de las células óseas y la osteointegración completa del implante.

To determine the biological response of **gmi** implants, in vivo studies were conducted by inserting the implants on animals, leaving them without load during the healing process and performing a histological study to prove the excellent response of the bone cells and the complete osseointegration of the implant.

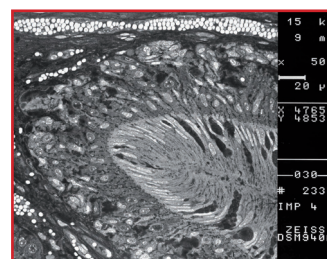
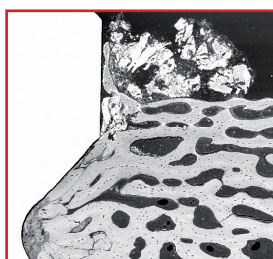
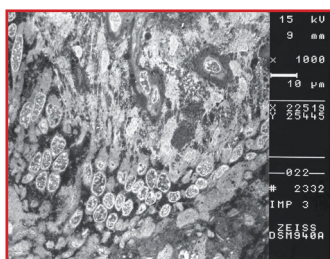

SEM-BSE: detalles ultraestructurales de las células en biofilm sobre el implante. • SEM-BSE: Ultrastructural details of cells in biofilm on the implant.

Recomendaciones de uso - Recommendations of use

La gama de implantes **gmi** modelo **frontier** ha sido diseñada y testada para ser colocada como restauración unitaria, con una inclinación máxima de 30 grados respecto al plano perpendicular al plano oclusal, según el siguiente diagrama.

The **gmi frontier** implant range was designed and tested to be inserted as a single restoration, with a 30-degree maximum inclination to the perpendicular plane to the occlusal plane, in accordance with the following diagram.

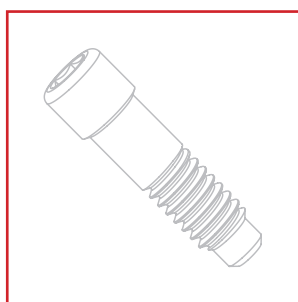
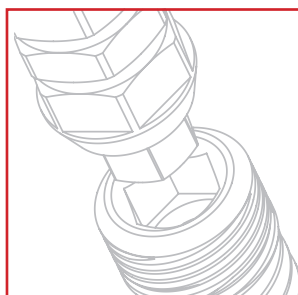
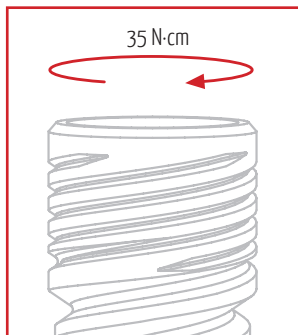
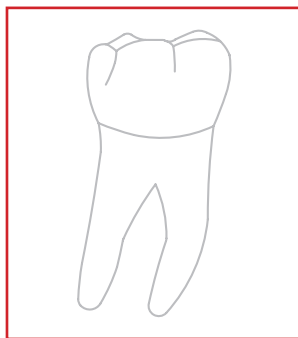

ø3,30-ø3,75 mm

Incisivos
(Excepto centrales maxilares)
Incisors
(Except central maxillary incisors)

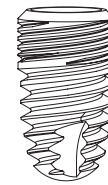

ø4,25 mm

Caninos • Canines
Premolares • Premolars
Incisivos centrales maxilares
Central maxillary incisors

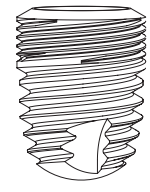

ø4,75-ø5,75 mm

Molares
Molars

Los implantes **gmi** modelo **frontier** han sido diseñados para ser insertados aplicando un par de apriete de 35-40 N-cm, aunque pueden soportar un par máximo de apriete de 60 N-cm. **gmi** recomienda la inserción manual del implante con la llave de carraca dinamométrica para asegurar que no se sobrepasan estos valores.

The **gmi frontier** implant range is designed to be inserted applying a 35-40 N-cm torque, although it can bear a maximum tightening torque of 60 N-cm. **gmi** recommends manual insertion of the implant with a dynamometric ratchet wrench to ensure that these values are not exceeded.

La gama de implantes y aditamentos protésicos **gmi** modelo **frontier**, han sido diseñados y fabricados con unas tolerancias estudiadas para mantener unos ajustes que minimizan el juego entre los componentes, y por tanto garantizan la estabilidad de la conexión. **gmi** recomienda utilizar aditamentos originales para asegurar el perfecto ajuste entre los componentes de la restauración.

The **gmi frontier** range of implants and prosthetic attachments are designed and manufactured with tolerances intended to maintain adjustments that minimize the clearance between components and therefore guarantee the stability of the connection. **gmi** recommends the use of original attachments to ensure a perfect fit between the components of the restoration.

Para evitar deformaciones previas del tornillo clínica, **gmi** recomienda reservar su uso únicamente para el apriete definitivo de la prótesis. Para realizar los ajustes de la fase protésica se recomienda utilizar el tornillo laboratorio.

To prevent prior deformation of the clinic screw, **gmi** recommends restricting its use only for the final tightening of the prosthesis. To make adjustments during the prosthetic procedures, use of the laboratory screw is recommended.

Descripción del etiquetado - Labelling description

En la tabla se detallan todos los símbolos que aparecen en las etiquetas y cajas del sistema de implantes **gmi frontier**, con su correspondiente descripción.

In the chart are detailed all the symbols appearing on the **gmi frontier** implant system's labelling and packaging and their corresponding description.

1	REF	Referencia - Reference
2	LOT	Número de Lote - Batch code
3		Fecha de caducidad - Used-by-date
4	UDI	Identificador único de producto Unique device identifier
5	MD	Dispositivo médico - Medical device
6		Fabricante - Manufacturer
7	STERILE R	Esterilizado usando radiación gamma Sterilized using gamma radiation
8		Sistema de barrera estéril único con embalaje de protección exterior Single sterile barrier system with protective packaging outside
9		De un solo uso - Single use only
10		No utilizar si el envase está dañado o abierto Do not use if packaging is damaged or opened
11		No reesterilizar - Do not resterilize
12	MR	RM Condicional: los dispositivos no suponen ningún peligro conocido en un entorno RM específico con condiciones de uso concretas MR Conditional: Items do not pose any known hazards in a specific MR environment with specific conditions of use.
13		Fecha de fabricación Manufacturing date
14		Instrucciones de uso electrónicas* Electronic instructions for use*
15	CE 2797	Marco de conformidad europeo European conformity mark
16	Rx Only	Venta limitada a dentistas o médicos autorizados Sale by or on the order of a licensed dentist
17		No estéril - Non-sterile

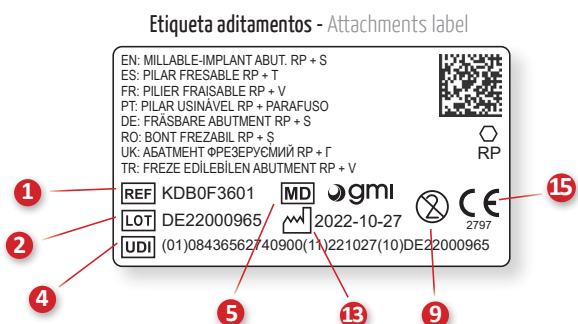
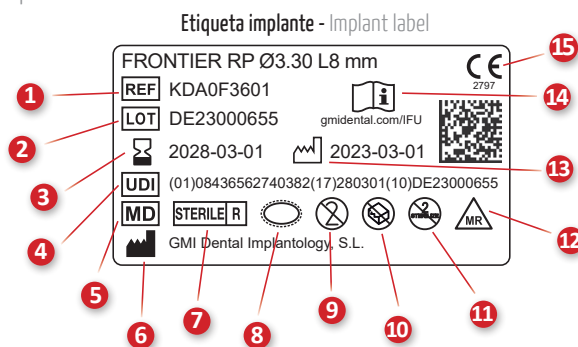

Caja - Packaging
Connection and platform



Sobre aditamentos
Attachments packaging



Especificaciones del DataMatrix de las etiquetas - DataMatrix specifications of labels

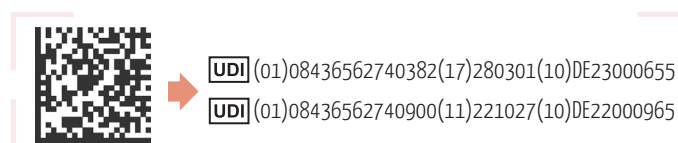

- 01 - GTIN del producto etiquetado - Tagged product GTIN
- 17 - Fecha de caducidad (año/mes/día) - Used-by-date (year/month/day)
- 11 - Fecha de fabricación (año/mes/día) - Manufacturing date (year/month/day)
- 10 - Número de Lote - Batch code

*Requisitos mínimos para abrir y descargar las instrucciones de uso electrónicas:
- Conectividad estable a internet.
- Un dispositivo con un sistema operativo moderno que admita la visualización de PDF.
- Espacio de almacenamiento adecuado en su dispositivo.
- Un navegador web como Google Chrome, Mozilla Firefox, Safari, Microsoft Edge u Opera instalado en su dispositivo.
- Una aplicación de lectura de PDF instalada en su dispositivo.

*Minimum requirements for downloading and opening the electronic instructions for use:
- Stable internet connectivity.
- A device with a modern operating system that supports PDF viewing.
- Adequate storage space on your device.
- A web browser such as Google Chrome, Mozilla Firefox, Safari, Microsoft Edge or Opera installed on your device.
- A PDF reader application installed on your device.

Implantes dentales gmi frontier - gmi frontier dental implants

Los implantes de conexión interna hexagonal **gmi** modelo **frontier** están mecanizados en titanio grado IV c.p. de la máxima calidad, garantizando así una gran estabilidad química y por tanto una excelente bio-compatibilidad. La capa de dióxido de titanio, que se forma en la superficie del implante después del proceso de pasivado, y el estudiado diseño del perfil exterior de la rosca aseguran una buena osteointegración y una elevada estabilidad.

La rosca exterior de doble entrada del implante permite disminuir los tiempos quirúrgicos. Además, las formas redondeadas, los fresados auto-roscentes y la ligera conicidad apical facilitan la inserción del implante disminuyendo las tensiones producidas en la interfase hueso-implante, y por tanto evitando los problemas asociados al estrés de roscado.

gmi frontier internal connection hexagonal implants are machined in c.p. grade IV titanium of the highest quality, thus ensuring a high chemical stability and excellent biocompatibility. The titanium oxide layer, that is formed on the implant surface after the passivation process, and the careful design of the outer surface of the thread, guarantee good osseointegration and high stability.

The external dual inlet thread of the implant helps to reduce surgery time. Moreover, the rounded shapes, self-threading millings and slight tapering facilitate implant insertion, reducing tension at the bone-implant interface and thus preventing threading stress-related problems.

Características generales

Key features

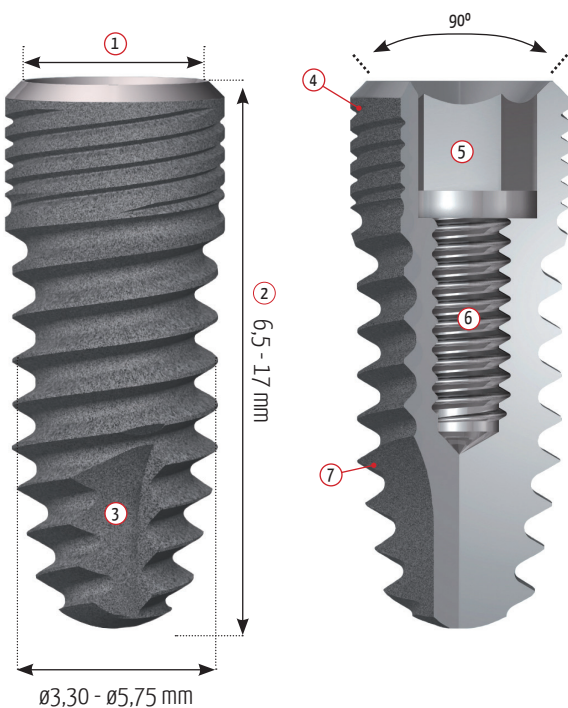

- ① Plataformas
RP: estándar ø3,30 mm
WP: ancha ø4,30 mm
- ② Longitud
- ③ Fresados auto-roscentes
Longitud variable
3 fresados a 120°
Ápice atraumático
- ④ Rosca cortical
- ⑤ Hexágono interno
E/C 2,45 mm x 1,50 mm
- ⑥ Rosca interior
M1,8 x 0,35 mm
- ⑦ Cuerpo del implante
Paso: 1,60 mm

- ① Platforms
RP: Standard ø3.30 mm
WP: Wide ø4.30 mm
- ② Length
- ③ Self threading millings
Variable length
3 millings at 120°
Atraumatic tip
- ④ Cortical thread
- ⑤ Internal hexagon
B/F 2.45 mm x 1.50 mm
- ⑥ Internal thread
M1.8 x 0.35 mm
- ⑦ Implant body
Pitch: 1.60 mm



	●	●	●	●	●
①	RP	RP	RP	WP	WP
②	De 8 a 15 From 8 to 15	De 8 a 17 From 8 to 17	De 6,5 a 17 From 6.5 to 17	De 6,5 a 13 From 6.5 to 13	De 6,5 a 13 From 6.5 to 13
④	ø3,60	ø4,00	ø4,50	ø5,00	ø6,00
⑦	ø3,30	ø3,75	ø4,25	ø4,75	ø5,75

Protocolo de inserción de implantes gmi frontier - Insertion sequence for gmi frontier implants

Los implantes de conexión interna **gmi frontier** vienen presentados en una caja de cartón serigrafiada, en cuyo interior se encuentran las etiquetas de trazabilidad y un doble envase que contiene el sistema de implantes, siendo el envase secundario de plástico técnico y el envase primario de vidrio Pyrex para asegurar el comportamiento inerte del envase. Una vez envasados en sala blanca, son esterilizados mediante radiación gamma según normativa.

El nuevo sistema de envasado de los implantes **gmi frontier** consta de un soporte de titanio donde se aloja únicamente el implante dental preparado para ser introducido directamente en boca, utilizando una única llave transportador hex-2,45 mm, diseñada a tal efecto. Este nuevo sistema presenta las siguientes ventajas para el profesional: un mayor control y una mejor visibilidad del proceso de inserción del implante, una mayor facilidad de uso en espacios interdentes reducidos y una reducción en el tiempo de cirugía.*

gmi frontier internal connection implants are packed in a screen-printed cardboard box, with the traceability labels and a double packaging containing the implant system, with the secondary packaging made of technical plastic and the primary packaging made of Pyrex glass to ensure the inert performance of the container. Once packaged in a clean room, they are sterilized with gamma radiation according to regulations.

The new packaging system of the **gmi frontier** implants consists of a titanium support which only houses the dental implant, prepared to be inserted directly into the mouth, using a single hex-2.45 mm implant carrier wrench, designed for this purpose. This new system offers the odontologist the following advantages: more control and a better view of the implant insertion process, it is easier to use in reduced interdental spaces and a reduction in surgery time.*



* Consultar las instrucciones de uso en formato electrónico.

1. Comprobar pegatina indicadora de diámetro y longitud del implante y abrir la caja de cartón.
2. Extraer el envase secundario y las etiquetas identificativas del producto.
3. Comprobar integridad del precinto de seguridad y desenroscar el tapón del envase secundario.
4. Extraer el envase primario del envase secundario evitando golpearlo contra una superficie rígida.
5. Extraer y guardar el tapón del envase primario, efectuando un movimiento lateral.
6. Introducir la llave-transportador HEX-2,45 mm hasta notar una ligera retención, encarando el hexágono de la llave con las caras del hexágono del implante.
7. Comprobar que la llave está totalmente insertada y efectuar un pequeño giro mientras se estira con suavidad el conjunto.
8. Colocar el implante en el lecho óseo aplicando un par de 35 N-cm hasta que la parte tratada quede a nivel crestal o subcrestal. Extraer la llave.
9. Extraer el tapón de cierre del tapón primario, utilizando la llave de HEX-1,20 mm.
10. Roscar el tapón de cierre al implante aplicando un par máximo de 15 N-cm. Extraer llave y suturar incisión.

* Consult the instructions for use in electronic format.

1. Check sticker indicating implant diameter and length and open the carton.
2. Remove the secondary packaging and product identification labels.
3. Check the integrity of the safety seal and unscrew the plug on the secondary packaging.
4. Remove the primary packaging from the secondary packaging avoiding hitting it against a hard surface.
5. Extract and save the primary packaging plug making a lateral movement.
6. Insert the HEX-2.45 mm implant carrier wrench until a slight retention is noticed, addressing the hex of the key with the faces of the implant hex broaching.
7. Check that the key is fully inserted and turn slightly while gently pulling on the assembly.
8. Place the implant in the bone bed by applying a torque of 35 N-cm until the treated area is at the crestal or subcrestal level. Remove the key.
9. Remove the cover screw from the primary packaging plug, using the HEX-1.20 mm wrench.
10. Screw the cover screw to the implant by applying a maximum torque of 15 N-cm. Remove key and suture the incision.

Gama de implantes gmi frontier - gmi frontier implants range

Implantes frontier ø3,30 mm plataforma RP
 frontier ø3.30 implants with RP platform

L (mm)	Ref.
8,00	KDA0F3601
10,00	KDA0F3602
11,50	KDA0F3603
13,00	KDA0F3604
15,00	KDA0F3605



Implantes frontier ø3,75 mm plataforma RP
 frontier ø3.75 implants with RP platform

L (mm)	Ref.
8,00	KDA0F3606
10,00	KDA0F3607
11,50	KDA0F3608
13,00	KDA0F3609
15,00	KDA0F3610
17,00	KDA0F3611

Implantes frontier ø4,25 mm plataforma RP
 frontier ø4.25 implants with RP platform

L (mm)	Ref.
6,50	KDA0F3630
8,00	KDA0F3612
10,00	KDA0F3613
11,50	KDA0F3614
13,00	KDA0F3615
15,00	KDA0F3616
17,00	KDA0F3617

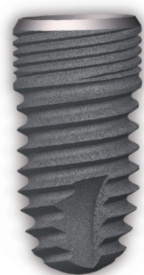
Gama de implantes gmi frontier - gmi frontier implants range



Implantes frontier ø4,75 mm plataforma WP frontier ø4.75 implants with WP platform

L (mm)	Ref.
6,50	KDA0F3631
8,00	KDA0F3622
10,00	KDA0F3623
11,50	KDA0F3624
13,00	KDA0F3625



Implantes frontier ø5,75 mm plataforma WP frontier ø5.75 implants with WP platform

L (mm)	Ref.
6,50	KDA0F3632
8,00	KDA0F3626
10,00	KDA0F3627
11,50	KDA0F3628
13,00	KDA0F3629

Secuencias fresado para implantes gmi frontier - Drilling sequences for gmi frontier implants

A continuación se describen las secuencias de fresado para los diferentes modelos de implantes de conexión interna y las condiciones de corte aconsejadas para su uso:

- Fresa lanza: 1200 - 1500 rpm.
- Fresa Piloto: 700 - 900 rpm.
- Fresas escalonadas:
 - ∅3.00 y ∅3.50 mm → 400 - 700 rpm.
 - ∅4.00 y ∅5.10 mm → 400 - 600 rpm.
- Fresas corticales: 200 - 400 rpm.

Para fresar es necesario disponer de refrigeración externa con solución salina.

The following is a description of the drilling sequences for the different internal connection implant models, as well as the recommended drilling conditions for their use:

- Lance-shaped drill: 1200 - 1500 rpm.
- Pilot drill: 700 - 900 rpm.
- Step drills:
 - ∅3.00 & ∅3.50mm → 400 - 700 rpm.
 - ∅4.00 & ∅5.10mm → 400 - 600 rpm.
- Cortical drills: 200 - 400 rpm.

For drilling, external cooling with saline solution is required.

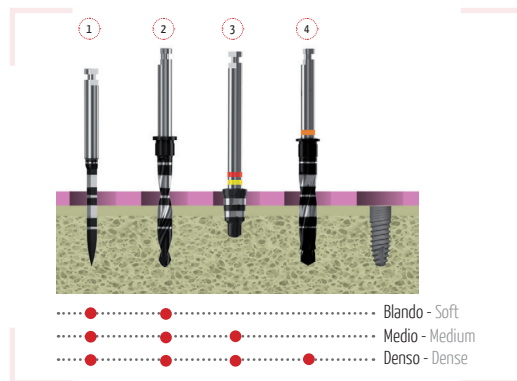

frontier Ø3,30			
Descripción - Description		Ref.	
1	Fresa lanza	Lance-shaped drill	KYFoC1225
2	Fresa piloto Ø2,50 mm	Pilot drill Ø2.50 mm	KYFoC2250
3	Fresa cortical Ø3,65 mm	Cortical drill Ø3.65 mm	KYFoC4336
4	Fresa escalonada Ø2,50/Ø3,00 mm	Step drill Ø2.50/Ø3.00 mm	KYFoC5130

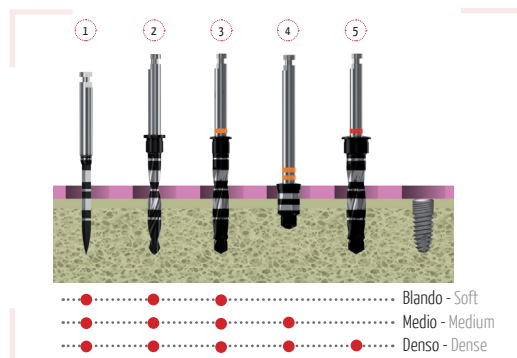

frontier Ø3,75			
Descripción - Description		Ref.	
1	Fresa lanza	Lance-shaped drill	KYFoC1225
2	Fresa piloto Ø2,50 mm	Pilot drill Ø2.50 mm	KYFoC2250
3	Fresa escalonada Ø2,50/Ø3,00 mm	Step drill Ø2.50/Ø3.00 mm	KYFoC5130
4	Fresa cortical Ø4,00 mm	Cortical drill Ø4.00 mm	KYFoC4340
5	Fresa escalonada Ø3,00/Ø3,50 mm	Step drill Ø3.00/Ø3.50 mm	KYFoC5135

Secuencias fresado para implantes gmi frontier - Drilling sequences for gmi frontier implants

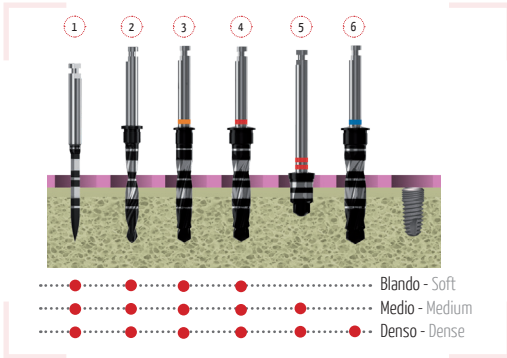

frontier $\varnothing 4,25$			
Descripción - Description		Ref.	
1	Fresa lanza	Lance-shaped drill	KYFoC1225
2	Fresa piloto $\varnothing 2,50$ mm	Pilot drill $\varnothing 2.50$ mm	KYFoC2250
3	Fresa escalonada $\varnothing 2,50/\varnothing 3,00$ mm	Step drill $\varnothing 2.50/\varnothing 3.00$ mm	KYFoC5130
4	Fresa escalonada $\varnothing 3,00/\varnothing 3,50$ mm	Step drill $\varnothing 3.00/\varnothing 3.50$ mm	KYFoC5135
5	Fresa cortical $\varnothing 4,50$ mm	Cortical drill $\varnothing 4.50$ mm	KYFoC4345
6	Fresa escalonada $\varnothing 3,50/\varnothing 4,00$ mm	Step drill $\varnothing 3.50/\varnothing 4.00$ mm	KYFoC5140

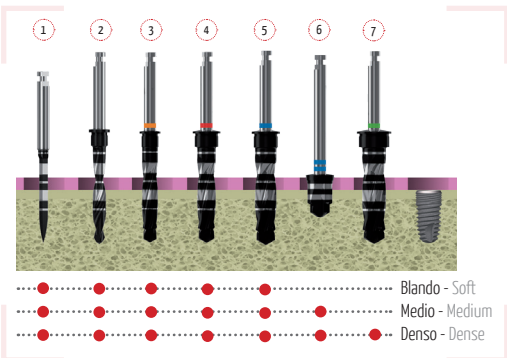

frontier $\varnothing 4,75$			
Descripción - Description		Ref.	
1	Fresa lanza	Lance-shaped drill	KYFoC1225
2	Fresa piloto $\varnothing 2,50$ mm	Pilot drill $\varnothing 2.50$ mm	KYFoC2250
3	Fresa escalonada $\varnothing 2,50/\varnothing 3,00$ mm	Step drill $\varnothing 2.50/\varnothing 3.00$ mm	KYFoC5130
4	Fresa escalonada $\varnothing 3,00/\varnothing 3,50$ mm	Step drill $\varnothing 3.00/\varnothing 3.50$ mm	KYFoC5135
5	Fresa escalonada $\varnothing 3,50/\varnothing 4,00$ mm	Step drill $\varnothing 3.50/\varnothing 4.00$ mm	KYFoC5140
6	Fresa cortical $\varnothing 4,90$ mm	Cortical drill $\varnothing 4.90$ mm	KYFoC4349
7	Fresa escalonada $\varnothing 4,00/\varnothing 4,50$ mm	Step drill $\varnothing 4.00/\varnothing 4.50$ mm	KYFoC5145

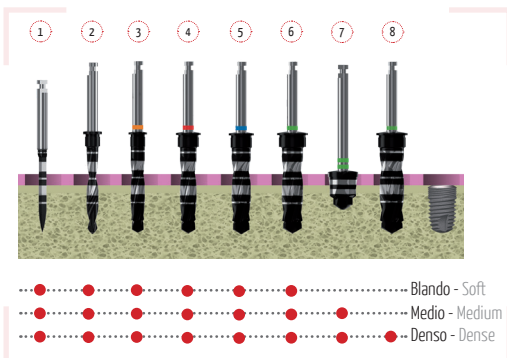

frontier $\varnothing 5,75$			
Descripción - Description		Ref.	
1	Fresa lanza	Lance-shaped drill	KYFoC1225
2	Fresa piloto $\varnothing 2,50$ mm	Pilot drill $\varnothing 2.50$ mm	KYFoC2250
3	Fresa escalonada $\varnothing 2,50/\varnothing 3,00$ mm	Step drill $\varnothing 2.50/\varnothing 3.00$ mm	KYFoC5130
4	Fresa escalonada $\varnothing 3,00/\varnothing 3,50$ mm	Step drill $\varnothing 3.00/\varnothing 3.50$ mm	KYFoC5135
5	Fresa escalonada $\varnothing 3,50/\varnothing 4,00$ mm	Step drill $\varnothing 3.50/\varnothing 4.00$ mm	KYFoC5140
6	Fresa escalonada $\varnothing 4,00/\varnothing 4,50$ mm	Step drill $\varnothing 4.00/\varnothing 4.50$ mm	KYFoC5145
7	Fresa cortical $\varnothing 5,90$ mm	Cortical drill $\varnothing 5.90$ mm	KYFoC4359
8	Fresa escalonada $\varnothing 4,50/\varnothing 5,10$ mm	Step drill $\varnothing 4.50/\varnothing 5.10$ mm	KYFoC5151

Implantes dentales gmi frontier PEAK - gmi frontier PEAK dental implants

Los implantes de conexión interna hexagonal gmi modelo frontier PEAK están mecanizados en titanio grado IV c.p. de la máxima calidad, garantizando así una gran estabilidad química y por tanto una excelente bio-compatibilidad. La capa de dióxido de titanio, que se forma en la superficie del implante después del proceso de pasivado, y el estudiado diseño del perfil exterior de la rosca aseguran una buena osteointegración y una elevada estabilidad.

La rosca exterior de doble entrada del implante permite disminuir los tiempos quirúrgicos. Además, el núcleo cónico y el perfil de rosca progresiva facilitan la inserción del implante y actúan como un compactador óseo permitiendo obtener una elevada estabilidad primaria en huesos poco densos.

gmi frontier PEAK internal connection hexagonal implants are machined in c.p. grade IV titanium of the highest quality, thus ensuring a high chemical stability and excellent biocompatibility. The titanium oxide layer, that is formed on the implant surface after the passivation process, and the careful design of the outer surface of the thread, guarantee good osseointegration and high stability.

The external dual inlet thread of the implant helps to reduce surgery time. Moreover, the conical core and progressive thread profile facilitate implant insertion and act as a bone compactor allowing high primary stability to be obtained in sparse bones.

Características generales

Key features

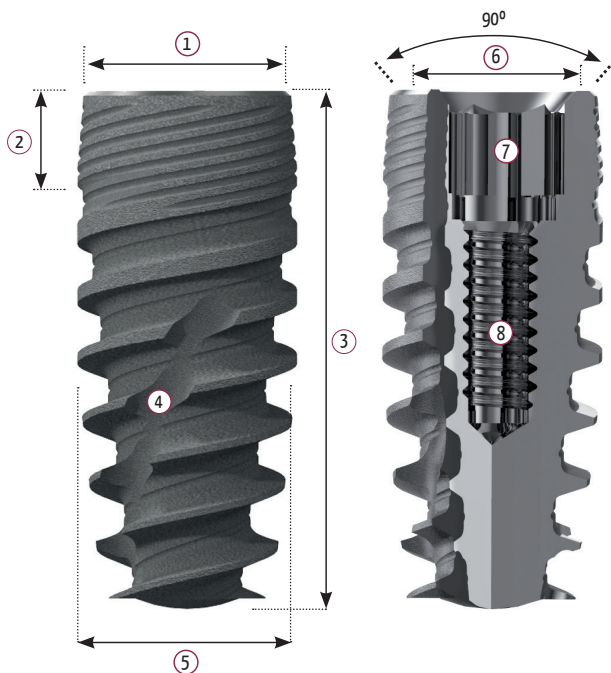

① Ø plataforma

② Rosca cortical
1,50 mm

③ Longitud

④ Fresados auto-roscentes
Longitud variable
2 fresados a 180°
Ápice atraumático
Corte en ambas direcciones

⑤ Cuerpo del implante
Paso: 2,40 mm

⑥ Conexión
RP: estándar Ø3,30 mm

⑦ Hexágono interno
E/C 2,45 mm x 1,50 mm

⑧ Rosca interior
M1,8 x 0,35 mm

① Platform Ø

② Cortical thread
1.50 mm

③ Length

④ Self threading millings
Variable length
2 millings at 180°
Atraumatic tip
Cut in both directions

⑤ Implant body
Pitch: 2.40 mm

⑥ Connection
RP: standard Ø3.30 mm

⑦ Internal hexagon
B/F 2.45 mm x 1.50 mm

⑧ Internal thread
M1.8 x 0.35 mm

	●	●	●
①	Ø3,70	Ø4,00	Ø4,30
③	De 8 a 15 From 8 to 15	De 6,5 a 13 From 6.5 to 13	De 6,5 a 13 From 6.5 to 13
⑤	Ø3,75	Ø4,25	Ø4,75
⑥	RP	RP	RP

Protocolo de inserción de implantes gmi frontier PEAK - Insertion sequence for gmi frontier PEAK implants

Los implantes de conexión interna gmi frontier PEAK vienen presentados en una caja de cartón serigrafiada, en cuyo interior se encuentran las etiquetas de trazabilidad y un doble envase que contiene el sistema de implantes, siendo el envase secundario de plástico técnico y el envase primario de vidrio Pyrex para asegurar el comportamiento inerte del envase. Una vez envasados en sala blanca, son esterilizados mediante radiación gamma según normativa.

El nuevo sistema de envasado de los implantes gmi frontier PEAK consta de un soporte de titanio donde se aloja únicamente el implante dental preparado para ser introducido directamente en boca, utilizando una única llave transportador hex-2,45 mm, diseñada a tal efecto. Este nuevo sistema presenta las siguientes ventajas para el profesional: un mayor control y una mejor visibilidad del proceso de inserción del implante, una mayor facilidad de uso en espacios interdentaes reducidos y una reducción en el tiempo de cirugía.*

gmi frontier PEAK internal connection implants are packed in a screen-printed cardboard box, with the traceability labels and a double packaging containing the implant system, with the secondary packaging made of technical plastic and the primary packaging made of Pyrex glass to ensure the inert performance of the container. Once packaged in a clean room, they are sterilized with gamma radiation according to regulations.

The new packaging system of the gmi frontier PEAK implants consists of a titanium support which only houses the dental implant, prepared to be inserted directly into the mouth, using a single hex-2.45 mm implant carrier wrench, designed for this purpose. This new system offers the odontologist the following advantages: more control and a better view of the implant insertion process, it is easier to use in reduced interdental spaces and a reduction in surgery time.*



* Consultar las instrucciones de uso en formato electrónico.

1. Comprobar pegatina indicadora de diámetro y longitud del implante y abrir la caja de cartón.
2. Extraer el envase secundario y las etiquetas identificativas del producto.
3. Comprobar integridad del precinto de seguridad y desenroscar el tapón del envase secundario.
4. Extraer el envase primario del envase secundario evitando golpearlo contra una superficie rígida.
5. Extraer y guardar el tapón del envase primario, efectuando un movimiento lateral.
6. Introducir la llave-transportador HEX-2,45 mm hasta notar una ligera retención, encarando el hexágono de la llave con las caras del hexágono del implante.
7. Comprobar que la llave está totalmente insertada y efectuar un pequeño giro mientras se estira con suavidad el conjunto.
8. Colocar el implante en el lecho óseo aplicando un par de 35 N-cm hasta que la parte tratada quede a nivel crestal o subcrestal. Extraer la llave.
9. Extraer el tapón de cierre del tapón primario, utilizando la llave de HEX-1,20 mm.
10. Roscar el tapón de cierre al implante aplicando un par máximo de 15 N-cm. Extraer llave y suturar incisión.

* Consult the instructions for use in electronic format.

1. Check sticker indicating implant diameter and length and open the carton.
2. Remove the secondary packaging and product identification labels.
3. Check the integrity of the safety seal and unscrew the plug on the secondary packaging.
4. Remove the primary packaging from the secondary packaging avoiding hitting it against a hard surface.
5. Extract and save the primary packaging plug making a lateral movement.
6. Insert the HEX-2.45 mm implant carrier wrench until a slight retention is noticed, addressing the hex of the key with the faces of the implant hex broaching.
7. Check that the key is fully inserted and turn slightly while gently pulling on the assembly.
8. Place the implant in the bone bed by applying a torque of 35 N-cm until the treated area is at the crestal or subcrestal level. Remove the key.
9. Remove the cover screw from the primary packaging plug, using the HEX-1.20 mm wrench.
10. Screw the cover screw to the implant by applying a maximum torque of 15 N-cm. Remove key and suture the incision.

Gama de implantes gmi frontier PEAK - gmi frontier PEAK implants range

Implantes frontier PEAK ø3,75 mm plataforma RP
 frontier PEAK ø3.75 implants with RP platform

L (mm)	Ref.
8,00	KDA0F3801
10,00	KDA0F3802
11,50	KDA0F3803
13,00	KDA0F3804
15,00	KDA0F3815

Implantes frontier PEAK ø4,25 mm plataforma RP
 frontier PEAK ø4.25 implants with RP platform

L (mm)	Ref.
6,50	KDA0F3805
8,00	KDA0F3806
10,00	KDA0F3807
11,50	KDA0F3808
13,00	KDA0F3809

Implantes frontier PEAK ø4,75 mm plataforma RP
 frontier PEAK ø4.75 implants with RP platform

L (mm)	Ref.
6,50	KDA0F3810
8,00	KDA0F3811
10,00	KDA0F3812
11,50	KDA0F3813
13,00	KDA0F3814

Secuencias fresado para implantes gmi frontier PEAK - Drilling sequences for gmi frontier PEAK implants

A continuación se describen las secuencias de fresado para los diferentes modelos de implantes de conexión interna y las condiciones de corte aconsejadas para su uso:

- Fresa inicial: 1000 rpm.
- Fresa piloto: 700-900 rpm.
- Fresas escalonadas y cónicas:
 - Ø2,00 / Ø2,80 mm → 500 - 700 rpm.
 - Ø3,20 / Ø3,65 mm → 500 - 700 rpm.
 - Ø3,70 / Ø4,15 mm → 400 - 700 rpm.
 - Ø4,15 / Ø4,65 mm → 400 - 600 rpm.
- Fresas corticales: 200 - 400 rpm.

Para fresar es necesario disponer de refrigeración externa con solución salina.

The following is a description of the drilling sequences for the different internal connection implant models, as well as the recommended drilling conditions for their use:

- Initial drill: 1000 rpm.
- Pilot drill: 700-900 rpm.
- Step and conical drills:
 - Ø2.00 / Ø2.80 mm → 500 - 700 rpm.
 - Ø3.20 / Ø3.65 mm → 500 - 700 rpm.
 - Ø3.70 / Ø4.15 mm → 400 - 700 rpm.
 - Ø4.15 / Ø4.65 mm → 400 - 600 rpm.
- Cortical drills: 200 - 400 rpm.

For drilling, external cooling with saline solution is required.

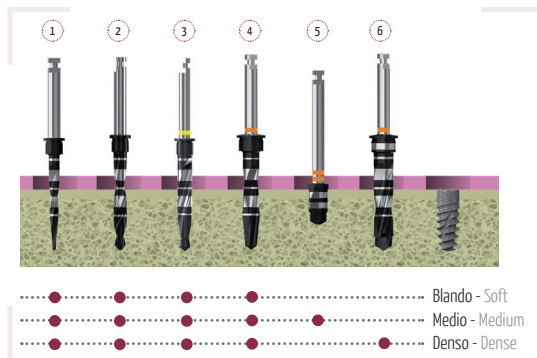

frontier PEAK Ø3,75		
Descripción - Description		Ref.
1	Fresa inicial / Initial drill	KYFoC1401
2	Fresa piloto Ø2,50 mm / Pilot drill Ø2.50	KYFoC2250
3	Fresa escalonada Ø2,50/Ø2,80 mm / Step drill Ø2.00/Ø2.80 mm	KYFoC5129
4	Fresa cónica Ø3,20 mm / Conical drill Ø3.20 mm	KYFoC7032
5	Fresa cortical Ø3,65 mm / Cortical drill Ø3.65	KYFoC4337
6	Fresa escalonada Ø3,20/Ø3,65mm / Step drill Ø3.20/Ø3.65mm	KYFoC5137

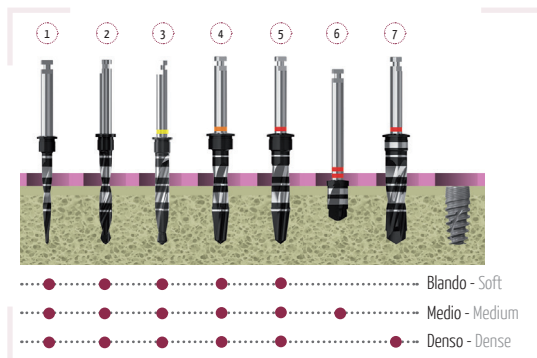

frontier PEAK Ø4,25		
Descripción - Description		Ref.
1	Fresa inicial / Initial drill	KYFoC1401
2	Fresa piloto Ø2,50 mm / Pilot drill Ø2.50	KYFoC2250
3	Fresa escalonada Ø2,50/Ø2,80 mm / Step drill Ø2.00/Ø2.80 mm	KYFoC5129
4	Fresa cónica Ø3,20 mm / Conical drill Ø3.20 mm	KYFoC7032
5	Fresa cónica Ø3,70 mm / Conical drill Ø3.70 mm	KYFoC7037
6	Fresa cortical Ø4,15 mm / Cortical drill Ø4.15 mm	KYFoC4342
7	Fresa escalonada Ø3,70/Ø4,15mm / Step drill Ø3.70/Ø4.15mm	KYFoC5142

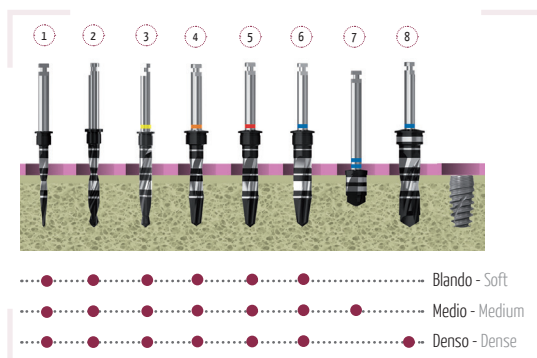

frontier PEAK Ø4,75		
Descripción - Description		Ref.
1	Fresa inicial / Initial drill	KYFoC1401
2	Fresa piloto Ø2,50 mm / Pilot drill Ø2.50	KYFoC2250
3	Fresa escalonada Ø2,50/Ø2,80 mm / Step drill Ø2.00/Ø2.80 mm	KYFoC5129
4	Fresa cónica Ø3,20 mm / Conical drill Ø3.20 mm	KYFoC7032
5	Fresa cónica Ø3,70 mm / Conical drill Ø3.70 mm	KYFoC7037
6	Fresa cónica Ø4,20 mm / Conical drill Ø4.20 mm	KYFoC7042
7	Fresa cortical Ø4,65 mm / Cortical drill Ø4.65 mm	KYFoC4347
8	Fresa escalonada Ø4,15/Ø4,65mm / Step drill Ø4.15/Ø4.65mm	KYFoC5147

* El proceso recomendado por GMI no puede sustituir el criterio y la experiencia del cirujano. - * Procedure recommended by GMI cannot replace the judgment and the experience of the surgeon.

Pilares de cicatrización gmi frontier - gmi frontier healing abutments

Una vez finalizada la fase de reparación de los tejidos de sostén del implante, en el caso de implantes cubiertos total o parcialmente por tejido blando, debe existir un canal o túnel mucoso que permita la conexión del implante a la estructura secundaria o prótesis. Los pilares de cicatrización son los encargados de formar esta vía mucosa una vez se ha abierto por incisión el tejido blando, se ha retirado el tapón de cierre y han sido roscados al implante.

Características principales

- Mecanizados en titanio grado V según norma ISO-5832.
- Apriete con llave hexagonal de e/c 1,20 mm.
- Apriete alternativo con destornillador de punta plana.
- Disponibles en alturas de emergencia de 2,00 a 6,00 mm.
- Mecha apical para facilitar el inicio de roscado.

Once the repair phase of the tissue supporting the implant has finished, in the case of implants fully or partially covered by soft tissue there must be a mucosal channel or tunnel enabling connection of the implant to the prosthesis or secondary structure. Healing abutments are used to form the mucosal route, once the soft tissue has been opened by incision and the cover screw has been withdrawn, by screwing them to the implant.

Key features

- Grade V titanium machining as per ISO-5832 standard.
- Tightening with b/f 1.20 mm hex wrench.
- Alternative tightening with a flat tip screwdriver.
- Available in emergency heights from 2.00 to 6.00 mm.
- Apical bit to facilitate the start of threading.

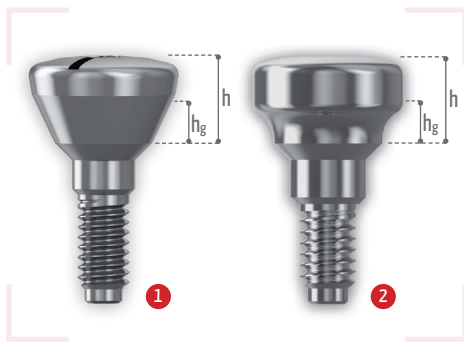

Pilares cicatrización - Healing abutments

Plataforma Platform	Ø cabeza Ø head	h	h gingival	Ref.
RP ● ●	Ø 4,00	2,00	1,00	KDPoC3601
		3,00	2,00	KDPoC3602
		4,00	3,00	KDPoC3603
		5,00	4,00	KDPoC3604

Pilares cicatrización anatómicos - Anatomical healing abutments

Plataforma Platform	Ø cabeza Ø head	h	h gingival	Ref.
RP ● ●	Ø 5,00	3,00	1,50	KDPoC3609 ¹
		3,00	1,50	KDPoC3617 ²
		4,00	2,50	KDPoC3618 ²
		5,00	3,50	KDPoC3619 ²
		6,00	4,50	KDPoC3620 ²

Pilares cicatrización - Healing abutments

Plataforma Platform	Ø cabeza Ø head	h	h gingival	Ref.
WP ●	Ø 5,00	2,00	1,00	KDPoC3605
		3,00	2,00	KDPoC3606
		4,00	3,00	KDPoC3607
		5,00	4,00	KDPoC3608

Pilares de cicatrización gmi frontier - gmi frontier healing abutments

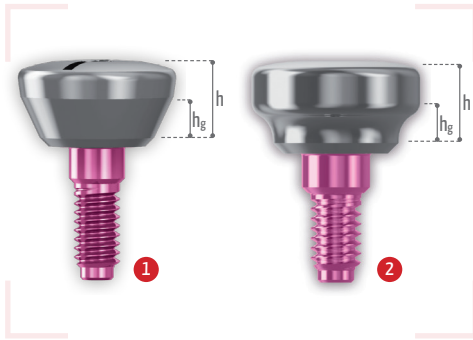

Pilares cicatrización anatómicos - Anatomical healing abutments

Plataforma Platform	Ø cabeza Ø head	h	h gingival	Ref.
WP ●	Ø 6,00	3,00	1,50	KDPoC3613 ①
		3,00	1,50	KDPoC3621 ②
		4,00	2,50	KDPoC3622 ②
		5,00	3,50	KDPoC3623 ②
		6,00	4,50	KDPoC3624 ②

Pilares fresables gmi frontier - gmi frontier millable-implant abutments

Cuando sea necesario utilizar un pilar a medida se utilizarán los pilares fresables, que permitirán, mediante el corte en cualquier dirección, adecuarse a las necesidades del protésico. Además y como función complementaria, los pilares fresables pueden ser utilizados como toma de impresión, roscándolos al implante mediante el tornillo de impresión corto y utilizándolos para hacer el negativo de la boca del paciente y su posterior positividad en escayola.

When the use of a custom abutment is required, millable abutments can be used. By cutting them in any direction, they can be suited to the needs of the prosthetic. In addition and as a complementary function, millable implant abutments can be used like impression coping, threading them to the implant screw through the short impression screw an using them to make the negative of the patient's mouth for subsequent positivation on plaster.

Características principales

- Mecanizados en titanio grado V según norma ISO-5832.
- Permiten corte en cualquier dirección adecuándose a las necesidades protésicas.
- Compatibles con llave hexagonal de e/c 4,00 mm para utilizar como transportador.
- Disponibles sólo en versión anti-rotatoria.
- Posibilidad de utilizarlos como toma de impresión con tornillo impresión corto.
- Incluye tornillo clínica ref: KDT0C3601.

Key features

- Grade V titanium machining as per ISO-5832 standard.
- They allow cutting in any direction to suit the needs of the prosthetic.
- Compatible with b/f 4.00 mm hex wrench for use as an implant carrier.
- Available only in non-rotary version.
- Possibility to use as impression coping with short impression screw.
- Clinic screw ref.: KDT0C3601 included.

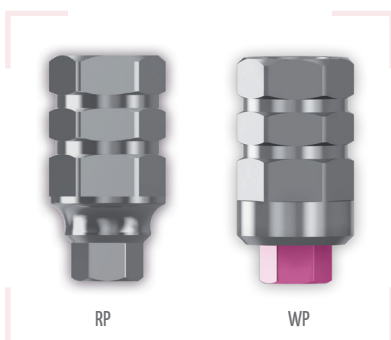

Plataforma Platform	Ref.
RP ●●	KDBoF3603
WP ●	KDBoF3602

Pilares inclinados gmi frontier - gmi frontier angled abutments

Cuando es necesario corregir una posición angular extrema del implante en el interior de la estructura ósea, en relación a las piezas naturales o implantes adyacentes, se utilizarán los pilares inclinados que, una vez montados y orientados sobre el implante, permitirán la paralelización de la nueva corona con el resto de estructuras.

Características principales

- Mecanizados en titanio grado V según norma ISO-5832.
- Permiten corregir disparalelismos de hasta 20 grados.
- Incluye tornillo clínica ref: KDT0C3601.
- Hombro del pilar adaptado a la forma de la encía.

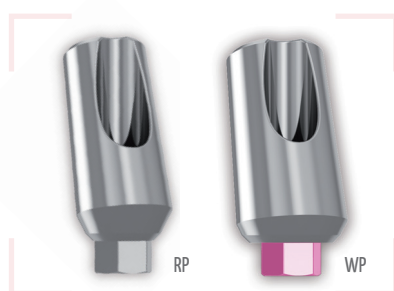
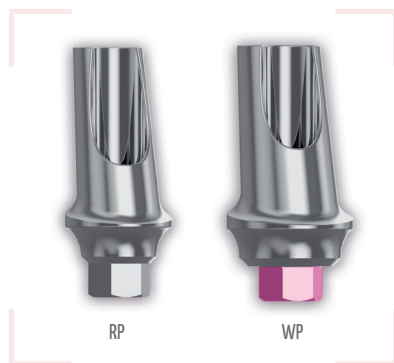

When it is necessary to correct an extreme angular position of the implant inside the bone structure in relation to adjacent natural or prosthetic teeth, angled abutments should be used. Once mounted and oriented on the implant, these abutments will allow the parallelization of the new crown with other structures.

Key features

- Grade V titanium machining as per ISO-5832 standard.
- Allow non-parallelism correction up to 20 degrees.
- Clinic screw ref.: KDT0C3601 included.
- Abutment shoulder adapted to the shape of the gum.

Pilares inclinados estéticos Esthetic angled abutments		
Plataforma Platform	Ang. (°)	Ref.
RP ●●	15°	KDMoF3634
	15°	KDMoF3654
	20°	KDMoF3635
	20°	KDMoF3656
WP ●	15°	KDMoF3636
	15°	KDMoF3655
	20°	KDMoF3637
	20°	KDMoF3657

Pilares inclinados Angled abutments		
Plataforma Platform	Ang. (°)	Ref.
RP ●●	20°	KDMoF3613
WP ●	20°	KDMoF3614

Pilares rectos gmi frontier - gmi frontier straight abutments

Una vez formado el túnel mucoso por el pilar de cicatrización y retirado este de su localización, se procede a utilizar el pilar correspondiente, que se define como el aditamento mecanizado cónico que una vez fijado con el tornillo clínica a la parte superior del implante sirve de soporte para la corona clínica fijándose a ésta mediante la utilización de cemento.

Características principales

- Mecanizados en titanio grado V según norma ISO-5832.
- Planos anti-rotatorios para facilitar la retención.
- Versión anti-rotatoria hexagonal e/c 2,45 mm.
- Tornillo clínica incluido ref: KDT0C3601.
- Disponibles en tres alturas de emergencia de 1,50 a 3,50 mm.

Once the mucosal tunnel has been formed by the healing abutment and after removing it from this location, it is appropriate to use the abutment, which is defined as the machined tapered attachment that, after being fixed with the clinic screw to the top of the implant, acts as a support for the clinic crown and is attached to it using cement.

Key features

- Grade V titanium machining as per ISO-5832 standard.
- Anti-rotational planes to increase retention.
- Abutments in b/f 2.45 mm hex non-rotary version.
- Clinic screw ref: KDT0C3601 included.
- Available in three emergency heights from 1.50 to 3.50 mm.

Pilares rectos gmi frontier - gmi frontier straight abutments



Plataforma Platform	Altura (mm) Height (mm)	Ref.
RP ● ●	1,50	KDMoF3628
	2,50	KDMoF3629
	3,50	KDMoF3630



Plataforma Platform	Altura (mm) Height (mm)	Ref.
WP ●	1,50	KDMoF3631
	2,50	KDMoF3632
	3,50	KDMoF3633

Pilares provisionales rectos gmi frontier - gmi frontier straight temporary cylinders

Cuando es necesario efectuar una restauración mientras se consolida la interfase hueso-implante se utilizan los pilares provisionales, que se definen como los aditamentos mecanizados en plástico técnico que, una vez fijados a la parte coronal del implante mediante el tornillo clínica, absorberán la mayoría de los esfuerzos de masticación evitando sobrecargar el implante mientras finaliza el proceso de osteointegración.

Características principales

- Mecanizado en plástico técnico de alta resiliencia.
- Hombro del pilar adaptado a la forma de la encía.
- Plano anti-rotatorio y regatas transversales para facilitar la retención.
- Tornillo clínica incluido ref: KDT0C3601

When it is necessary to perform a provisional restoration while the bone-implant interfaces or the soft tissues are healing, the temporary cylinder is used, defined as technical plastic machined attachment that once attached to the crown of the implant with clinic screw, will absorb most of the masticatory stresses while avoiding overloading the implant while the osseointegration process is completed.

Key features

- Machined in high strength technical plastic.
- Abutment shoulder adapted to the shape of the gum.
- Anti-rotational plane and transverse retention to provide good fixation.
- Clinic screw ref.: KDT0C3601 included.



Plataforma Platform	Tipo conexión Connection type	Ref.
RP ● ●	Anti-rotatoria · Non-rotary	KDHoF3605
	Rotatoria · Rotary	KDHoF3607
WP ●	Anti-rotatoria · Non-rotary	KDHoF3606
	Rotatoria · Rotary	KDHoF3608

Base titanio gmi frontier - gmi frontier titanium base

Una vez formado el túnel mucoso por el pilar de cicatrización y retirado este de su localización, se procede a utilizar la base de titanio correspondiente, que se define como el aditamento mecanizado cónico que una vez fijado con el tornillo clínica a la parte superior del implante sirve de soporte para una meso-estructura metálica o cerámica ya sea colada o mecanizada mediante CAD/CAM.

Características principales

- Mecanizados en titanio grado V según norma ISO-5832.
- Versión anti-rotatoria y rotatoria.
- Tornillo clínica incluido ref: KDT0C3601.
- Disponible en alturas de emergencia de 0,60 mm, 1,50 mm y 3,00 mm.
- Elemento anti-giro en base anti-rotatoria que permite indexación.
- Escaneo directo sobre la Base de titanio o escaneo alternativo sobre el Pilar de escaneo.

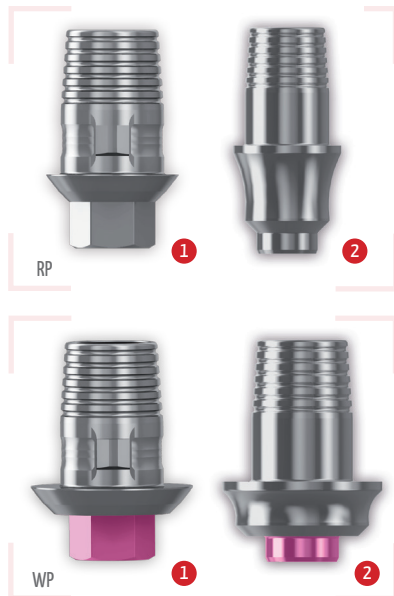

Once the mucosal tunnel has been formed by the healing abutment and after removing the cap from this location, it is appropriate to use the titanium base, which is defined as the machined tapered attachment that, after being fixed with the clinic screw to the top of the implant, acts as a support for a metallic or ceramic meso-structure casted or machined with CAD/CAM.

Key features

- Grade V titanium machining as per ISO-5832 standard.
- Non-rotary and rotary version.
- Clinic screw ref.: KDT0C3601 included.
- Available in emergency heights of 0.60 mm, 1.50 mm and 3.00 mm.
- Non-rotary titanium base with indexation.
- Scan directly on Titanium base or alternative scan on Scan abutment.

Base titanio - Titanium base

Plataforma Platform	Altura (mm) Height (mm)	Tipo conexión Connection type	Ref.
RP ●●	0,65*	Anti-rotatoria • Non-rotary	KDMoF3615 ①
	0,65*	Rotatoria • Rotary	KDMoF3616 ①
	1,50	Anti-rotatoria • Non-rotary	KDMoF3638 ②
	1,50	Rotatoria • Rotary	KDMoF3640 ②
	3,00	Anti-rotatoria • Non-rotary	KDMoF3639 ②
	3,00	Rotatoria • Rotary	KDMoF3641 ②
	4,50	Anti-rotatoria • Non-rotary	KDMoF3650 ②
	4,50	Rotatoria • Rotary	KDMoF3651 ②
WP ●	0,65*	Anti-rotatoria • Non-rotary	KDMoF3617 ①
	0,65*	Rotatoria • Rotary	KDMoF3618 ①
	1,50	Anti-rotatoria • Non-rotary	KDMoF3642 ②
	1,50	Rotatoria • Rotary	KDMoF3644 ②
	3,00	Anti-rotatoria • Non-rotary	KDMoF3643 ②
	3,00	Rotatoria • Rotary	KDMoF3645 ②
	4,50	Anti-rotatoria • Non-rotary	KDMoF3652 ②
	4,50	Rotatoria • Rotary	KDMoF3653 ②

* Utilizar el Pilar de cicatrización h=3 mm RP (KDPOC3609) y WP (KDPOC3613)

* Use the Healing abutment h=3 mm RP (KDPOC3609) and WP (KDPOC3613)

Calcinable - Castable

Plataforma Platform	Altura total (mm) Total Height (mm)	Cantidad (Ud.) Quantity (Un.)	Ref.
RP ●●	11,00	10	KDCoF3605
WP ●	11,00	10	KDCoF3606



Base titanio gmi frontier - gmi frontier titanium base

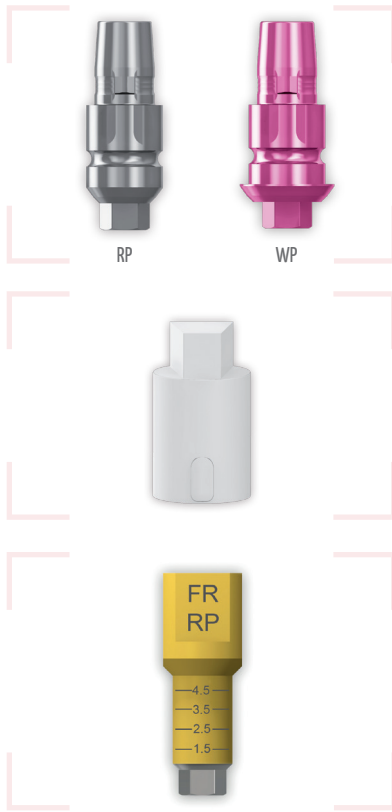

Pilar escaneado - Scanabutment

Plataforma Platform	Altura (mm) Height (mm)	Ref.
RP ●●	5,30	KDIOF3601
WP ●	5,30	KDIOF3602

Cuerpo pilar escaneado - Scanbody

Plataforma Platform	Altura (mm) Height (mm)	Ref.
RP - WP ●●	7,50	KDIOC4003

Scanbody de titanio - Titanium scanbody

Plataforma Platform	Altura (mm) Height (mm)	Ref.
RP ●●	11,20	KDIOF3603
WP ●	11,20	KDIOF3604

Pilares bola gmi frontier - gmi frontier ball abutments

Una vez formado el túnel mucoso por el pilar de cicatrización, y retirado este de su localización, se procede a utilizar el pilar bola correspondiente, que se define como el aditamento mecanizado que una vez fijado a la parte superior del implante sirve de elemento retentivo de la prótesis removible, la cual lleva incorporados previamente los casquillos de retención que se fijarán en la parte esférica superior de los pilares bola.

Once the healing abutment has formed the mucosal tunnel and the healing abutment has been removed from this location, the corresponding ball abutment is used, which is defined as a machined attachment being fixed to the top of the implant and serving as the retention element for the removable prosthesis, with the previous addition of the retention caps that will be fixed to the top spherical part of the ball abutment.

Características principales

- Mecanizados en titanio grado V según norma ISO-5832.
- Disponibles en alturas de emergencia de 1,00 a 4,00 mm.
- Cofia de retención rosa y contenedor incluidos.
- Disco de protección incluido.
- Apriete con llave hexagonal de e/c 2,45 mm ref: KYLOC0065.
- Instrumental para cofias: Insertador / extractor de cofias (RH4851C).

Key features

- Grade V titanium machining as per ISO-5832 standard.
- Available in emergency heights from 1.00 to 4.00 mm.
- Pink retention cap and metal container included.
- Protection disk included.
- Tightening with b/f 2.45 mm hex wrench, part no.: KYLOC0065.
- Instruments for caps: Insertion / removal tool for caps (RH4851C).

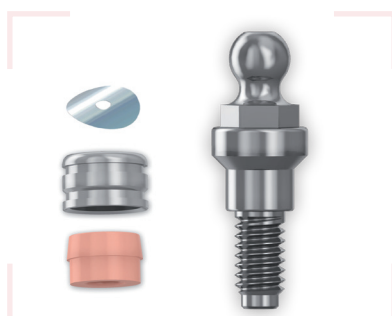

Plataforma Platform	Altura (mm) Height (mm)	Ref.
RP ●●	1,00	KDFoF3609
	2,00	KDFoF3610
	3,00	KDFoF3611
	4,00	KDFoF3612

Pilares bola gmi frontier - gmi frontier ball abutments



Retenciones Retention caps

Tipo retención Retainer type	Color	Cantidad (ud.) Quantity (Un)	Ref.
Suave • Soft (900 gr)	Rosa • Pink	6	RH40CRNSN
Fuerte • Strong (1300 gr)	Verde • Green	6	RH040CRN
Elástica • Elastic (500 gr)	Naranja • Orange	6	RH049PCN

Contenedor cofias Metal container

Cantidad (ud.) Quantity (Un)	Ref.
2	RH041CANB

Discos protección Protection disks

Cantidad (ud.) Quantity (Un)	Ref.
10	RH100PD

Pilares multi-estético gmi frontier - gmi frontier multi-esthetic abutments

Una vez efectuada la primera etapa de la cirugía, y por tanto obtenida la osteointegración del implante, se procede a utilizar el pilar multi-estético (PME), que se define como el aditamento mecanizado que una vez fijado a la parte coronal del implante sirve como soporte de una restauración múltiple, disminuyendo la altura entre la conexión del implante y la conexión de la estructura, y facilitando el ajuste pasivo de la estructura.

Características principales

- Mecanizados en titanio grado V según norma ISO-5832.
- Disponibles en alturas de emergencia de 1,00 a 4,50 mm.
- Pilares rectos de una sola pieza en versión rotatoria.
- Apriete con llaves hexagonales:
 - RP: E/C 2,00 mm (KYLoC0149)
 - WP: E/C 2,50 mm (KYLoC0098)
- Toma de impresión con tornillo incluido.
- Calcinable con tornillo clínica incluido.
- Cilindro provisional en titanio grado V según ISO-5832, con tornillo clínica incluido.
- Los PME inclinados permiten corregir disparalelismos de hasta 30 grados.

Following the first stage of surgery and therefore after implant osseointegration is achieved, the multi-esthetic abutment (MEA) is used, that is defined as the machined attachment that, after being attached to the crown of the implant, serves as a support for a multiple restoration, thus decreasing the height between the implant connection and the structure connection, and providing a passive adjustment of the structure.

Key features

- Grade V titanium machining as per ISO-5832 standard.
- Available in emergency heights from 1.00 to 4.50 mm.
- One-piece straight abutments in rotary model.
- Tightened with hex keys:
 - RP: B/F 2.00 mm (KYLoC0149)
 - WP: B/F 2.50 mm (KYLoC0098)
- Impression coping with screw included.
- Castable with clinic screw included.
- Temporary cylinder in grade V titanium as per ISO-5832 with clinic screw included.
- Angled multi-esthetic abutments allow non-parallelism up to 30°.

Pilares multi-estético gmi frontier - gmi frontier multi-esthetic abutments



Pilares multi-estético inclinados Multi-esthetic angled abutments

Plataforma Platform	Ang. (°)	Altura (mm) Height (mm)	Ref.
RP ● ●	17°	2,50	KDGoF3609
	17°	3,50	KDGoF3610
	30°	4,00	KDGoF3611

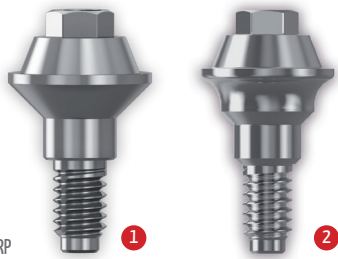

Pilares multi-estético rectos Multi-esthetic straight abutments

Plataforma Platform	Altura (mm) Height (mm)	Ref.
RP ● ●	1,00	KDGoC3601 ①
	1,50	KDGoC3620 ②
	2,50	KDGoC3621 ②
	3,50	KDGoC3622 ②
	4,50	KDGoC3623 ②
WP ●	1,00	KDGoC3605 ①
	1,50	KDGoC3624 ②
	2,50	KDGoC3625 ②
	3,50	KDGoC3626 ②
	4,50	KDGoC3627 ②

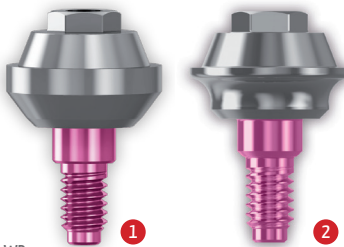

Pilares cicatrización PME Healing abutments MEA

Plataforma Platform	Ø Diámetro (mm) Ø Diameter (mm)	Ref.
RP ● ●	Ø 4,80	KDPoF0035
	Ø 6,00	KDPoF0037
WP ●	Ø 6,00	KDPoF0036

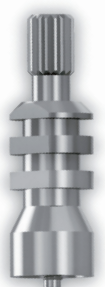

Tomas impresión cubeta abierta (CA) larga PME Open tray (OT) long impression coping MEA

Plataforma Platform	Ref.
RP ● ●	KDSoF0015
WP ●	KDSoF0016

Pilares multi-estético gmi frontier - gmi frontier multi-esthetic abutments

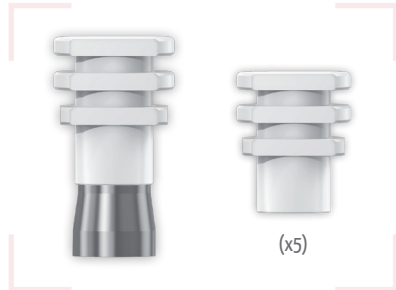
Toma impresión cubeta cerrada (CC) PME
Closed tray (CT) impression coping MEA

Plataforma Platform	Cantidad (Ud.) Quantity (Un.)	Ref.
RP ● ●	1	KDSOf0017
	5	KDSOf5001

Cilindros provisionales PME
Temporary cylinder MEA

Plataforma Platform	Ref.
RP ● ●	KDGoF0028
WP ●	KDGoF0029

Calcinables PME
Castables MEA

Plataforma Platform	Ref.
RP ● ●	KDCoF0117
WP ●	KDCoF0118

Base titanio PME
Titanium base MEA

Plataforma Platform	Ref.
RP ● ●	KDGoF0035
WP ●	KDGoF0036

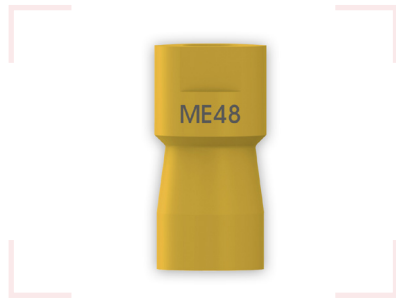
Scanbody de titanio PME
Titanium scanbody MEA

Plataforma Platform	Ref.
RP ● ●	KDIOF0002
WP ●	KDIOF0003

Bases bioestéticas gmi frontier - gmi frontier bioesthetic bases

Una vez finalizada la inserción del implante en el lecho óseo se procede a utilizar la base bioestética que se define como el aditamento mecanizado que una vez fijado a la parte coronal del implante permite efectuar restauraciones unitarias a nivel del pilar.

La colocación de la base bioestética durante la cirugía permite que los tejidos blandos cicatricen alrededor de ésta.

Una vez cicatrizado el tejido, sirve como base para efectuar la rehabilitación evitando la conexión y desconexión de los componentes al implante y, por tanto, manteniendo intacto el sellado biológico.

Características principales

- Mecanizados en titanio grado V según norma ISO-5832.
- Disponibles en alturas de emergencia de 1,00 a 4,00 mm.
- Bases rectas de dos piezas, incluyendo el tornillo.
- Apriete con llave hexagonal: E/C 2,00 mm (KYLoC0149).
- Toma de impresión con tornillo incluido.
- Calcinable.
- Pares apriete: Base BE (30 N-cm) y pilar cicatrización (Manual: Máx. 15 N-cm).

Once the insertion of the implant in the bone bed has been completed, the bioesthetic base is used, which is defined as the machined attachment that, once fixed to the coronal part of the implant, allows single restorations at the abutment level.

Placing the bioesthetic base during surgery allows the soft tissues to heal around it.

Once the tissue has healed, it serves as the basis for the rehabilitation, avoiding the connection and disconnection of the components to the implant and, therefore, keeping the biological seal intact.

Key features

- Grade V titanium machining as per ISO-5832 standard.
- Available in emergency heights from 1.00 to 4.00 mm.
- Straight two-piece bases, including the screw.
- Tightened with hex wrench: B/F 2.00 mm (KYLoC0149).
- Impression coping with screw included.
- Castable.
- Tightening torques: BE base (30 N-cm) and healing abutment (Manual: Max. 15 N-cm).

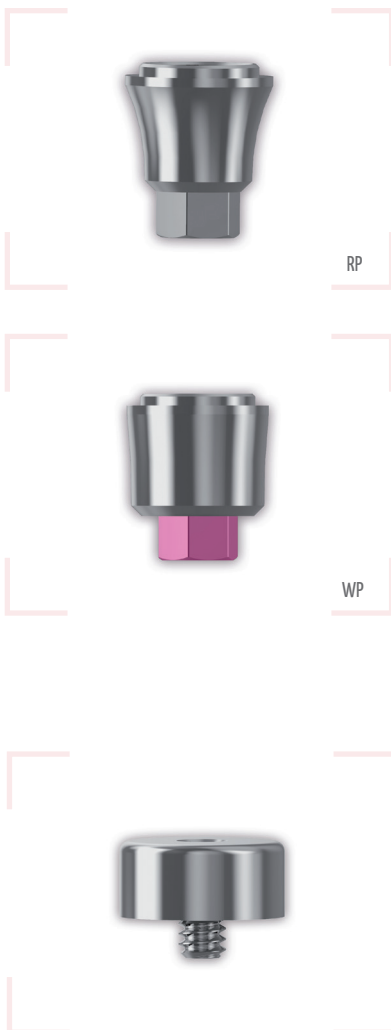

Bases bioestéticas Bioesthetic bases		
Plataforma Platform	Altura (mm) Height (mm)	Ref.
RP ●●	1,00	KDGoF3612
	2,00	KDGoF3613
	3,00	KDGoF3614
	4,00	KDGoF3615
WP ●	1,00	KDGoF3616
	2,00	KDGoF3617
	3,00	KDGoF3618
	4,00	KDGoF3619

Pilar cicatrización BE BE healing abutment		
Plataforma Platform	Ø Diámetro (mm) Ø Diameter (mm)	Ref.
RP - WP ●●	Ø 4,80	KDPoC0038

Bases bioestéticas gmi frontier - gmi frontier bioesthetic bases



Toma impresión cubeta abierta (CA) BE
BE open tray (OT) impression coping

Plataforma
Platform

Ref.

RP - WP ●●

KDSOf0018



Calcinable BE
BE castable

Plataforma
Platform

Cantidad
Quantity

Ref.

RP - WP ●●

10

KDCoF0019

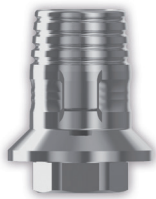

Base de titanio BE
BE titanium base

Plataforma
Platform

Ref.

RP - WP ●●

KDGoF4018



Scanbody de titanio BE
BE titanium scanbody

Plataforma
Platform

Ref.

RP - WP ●●

KDIOF0004

Réplicas gmi frontier - gmi frontier replicas

Una vez realizada la transferencia de la posición mediante la toma de impresión del medio biológico al modelo de trabajo de laboratorio, es necesario utilizar las réplicas, que se definen como el aditamento mecanizado destinado por una parte a reproducir la posición del implante en la boca del paciente a un modelo de trabajo y por otra a servir de modelo de conexión para la construcción en el laboratorio de la estructura destinada a efectuar la restauración.

Características principales

- Mecanizadas en titanio grado V según norma ISO-5832.
- Fresados anti-giro y cuello de retención vertical para una buena fijación.

Once the transfer of the position has been made using the impression copying from the biological medium to the laboratory working model, it is necessary to use replicas, which are defined as the machined attachments designed on one hand to reproduce the implant position in the mouth of the patient to a working model, and on the other to serve as a connection model for the construction in the laboratory of the structure to carry out the restoration.

Key features

- Grade V titanium machining as per ISO-5832 standard.
- Anti-rotation millings and vertical retention neck for a good fixation.

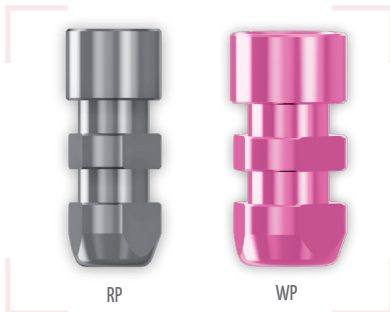

Réplicas de implante Implant replicas	
Plataforma Platform	Ref.
RP ●●	KDRoC3601
WP ●	KDRoC3602

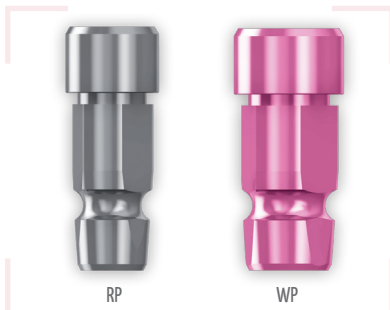

Réplicas digitales Digital replicas	
Plataforma Platform	Ref.
RP ●●	KDRoF3603
WP ●	KDRoF3604

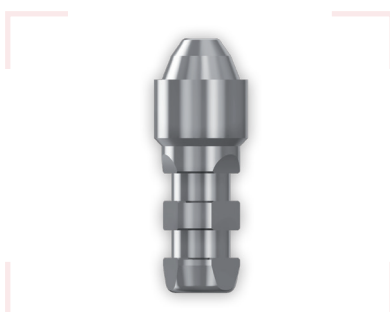

Réplicas para pilares multi-estético MEA replicas	
Plataforma Platform	Ref.
RP ●●	KDRoC0012
WP ●	KDRoC0013

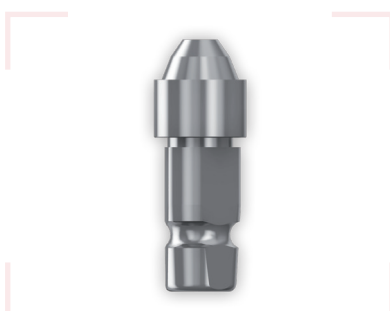

Réplicas digitales para pilares multi-estético MEA digital replicas	
Plataforma Platform	Ref.
RP ●●	KDRoF0014
WP ●	KDRoF0015

Réplicas gmi frontier - gmi frontier replicas



Réplica digital BE BE digital replica

Plataforma
Platform

Ref.

RP - WP ●●

KDR0F0016

Tomas de impresión gmi frontier - gmi frontier impression coping

Las tomas de impresión se definen como el aditamento mecanizado que conectado a la parte coronal del implante en el interior de la cavidad bucal, y fijado axialmente mediante el tornillo de impresión, sirve para realizar la transferencia de la posición del implante en el medio biológico a un modelo de laboratorio, sobre el cual trabajará el protésico para crear las coronas o prótesis dentales. Este proceso se consigue utilizando materiales de impresión que colocados de forma apropiada, se endurecen en la cavidad bucal permitiendo la obtención del negativo de la boca del paciente. Una vez extraído, se colocan las réplicas y se efectúa el vaciado de escayola para obtener el molde positivo donde la réplica quedará en la posición original del implante en boca.

Características principales

- Toma impresión CA mecanizada en titanio grado V según norma ISO-5832.
- Tornillos de impresión mecanizados en titanio grado V según norma ISO-5832.
- Apriete tornillos impresión con llave hexagonal de e/c 1,20 mm.
- Mecha apical para facilitar el inicio de roscado del tornillo impresión.
- Fresados anti-giro y cuello de retención vertical para una buena fijación.
- Tornillos de toma de impresión incluidos.
- Tornillo largo con fresados longitudinales para apriete manual.
- Toma de impresión CC mecanizada en plástico técnico.
- Conjunto de toma de impresión CC formado por toma impresión CC + pilar hexagonal + tornillo.

Impression coping are defined as the machined attachments that, connecting to the coronal part of the implant within the oral cavity and axially fixed by the impression screw, are used to make the transfer of the position of the implant in the biological medium to a laboratory model, on which the prosthetic will work to create the dental crowns or prostheses. This process is achieved using impression materials placed in an appropriate manner, that will harden in the oral cavity and produce the negative of the patient's mouth. Once extracted, replicas are placed and the casting plaster is poured to obtain the positive mould where the replica will be placed in the original position of the implant in the mouth.

Key features

- Machined open tray impression coping in grade V titanium according to ISO-5832.
- Impression screws in grade V titanium according to ISO-5832.
- Tightening of impression screws with b/f 1.20 mm hex wrench.
- Apical bit to facilitate the start of threading impression screw.
- Anti-rotation millings and vertical retention neck for a good fixation.
- Impression coping screw included.
- Long impression screw with longitudinal millings for manual tightening.
- CT impression coping machined in technical plastic.
- CT impression coping whole formed by CT impression coping + hexagonal abutment + screw.

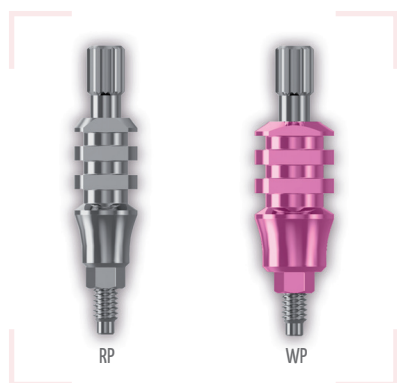

Tomas impresión cubeta abierta (CA) Open tray (OT) impression coping

Plataforma
Platform

Tornillo
Screw

Ref.

RP ●●

Corto • Short

KDS0F3608

Largo • Long

KDS0F3609

WP ●

Corto • Short

KDS0F3610

Largo • Long

KDS0F3611

Tomas de impresión gmi frontier - gmi frontier impression coping

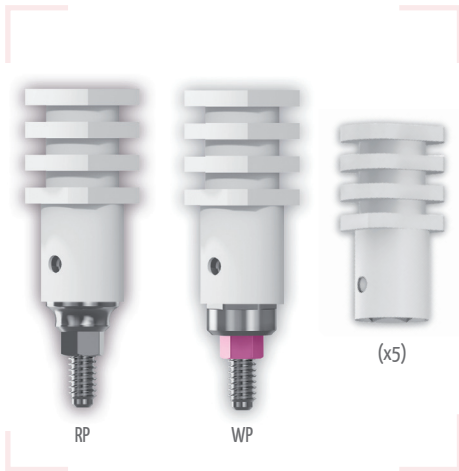

Tomas impresión cubeta cerrada (CC) Closed tray (CT) impression coping	
Plataforma Platform	Ref.
RP ● ●	KDS0F3612
	KDS0F3613
WP ●	KDS0F3607
	KDS0F3614
Cantidad (Ud.) Quantity (Un.)	Ref.
5 ● ●	KDS0F0014

Calcinables gmi frontier - gmi frontier castables

Para sustituir una corona dental con una prótesis de restauración se utiliza el calcinable, que se define como el aditamento mecanizado de plástico fundible que una vez posicionado sobre la parte coronal del implante de conexión interna servirá de base inicial para modelar la forma que tendrá la estructura final, que será colada en el metal correspondiente.

Características principales

- Calcinables mecanizados en material plástico fundible de color blanco.
- Fisiológicamente inertes y excelente estabilidad dimensional.
- Disponibles en versión rotatoria y anti-rotatoria.
- Incluye tornillo clínica ref: KDTC3601.

To replace a dental crown with a restoration dental prosthesis, a castable is used, which is defined as a meltable plastic machined attachment that, once positioned over the coronal part of the internal connection implant, will be the initial basis to model the form of the final structure, to be cast in the corresponding metal.

Key features

- Machined castables in white meltable plastic material.
- Physiologically inert and excellent dimensional stability.
- Available in rotary and non-rotary version.
- Clinic screw ref.: KDTC3601 included.

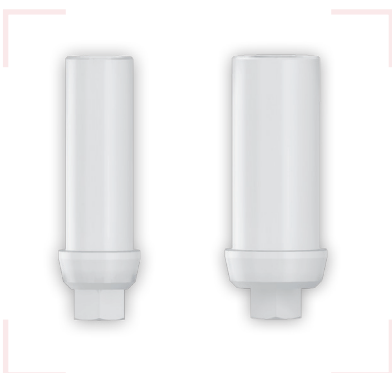

Plataforma Platform	Tipo de conexión Connection type	Ref.
RP ● ●	Anti-rotatoria · Non-rotary	KDC0F3611
	Rotatoria · Rotary	KDC0F3612
WP ●	Anti-rotatoria · Non-rotary	KDC0F3613
	Rotatoria · Rotary	KDC0F3614

Bases CrCo gmi frontier - gmi frontier CrCo bases

Las bases CrCo constan de una interfase de CrCo mecanizado y una chimenea calcinable. Esta configuración permite una mayor estabilidad dimensional en las superficies de contacto de la conexión entre el implante y el pilar.

Están indicadas para restauraciones unitarias o múltiples atornilladas ya sean mediante técnica convencional de sobrecolado o mediante soldadura láser.

The CrCo bases consist of a machined CrCo interface and a castable chimney. This configuration allows for greater dimensional stability at the contact surfaces of the implant-abutment connection.

They are indicated for single or multiple screw-retained restorations either by conventional cast-on technique or by laser welding.

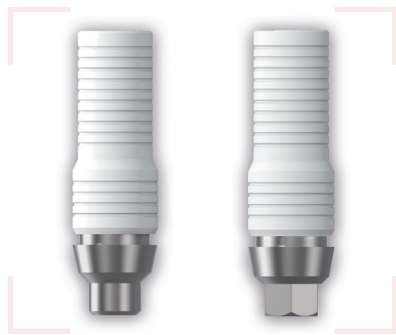

Plataforma Platform	Tipo de conexión Connection type	Ref.
RP ●●	Rotatoria • Rotary	TS30017
	Anti-rotatoria • Non-rotary	TS31017
WP ●	Rotatoria • Rotary	TS30018
	Anti-rotatoria • Non-rotary	TS31018

Tornillos clínica y laboratorio gmi frontier - gmi frontier clinic and laboratory screws

Los tornillos clínica se definen como los aditamentos mecanizados utilizados para el anclaje definitivo de los pilares, el pilar fresable o el calcinable directo al implante, mientras que los tornillos de laboratorio son los aditamentos mecanizados utilizados para el anclaje provisional de los calcinables a la réplica del implante, utilizados por el protésico en el laboratorio donde se construyen las coronas dentales o prótesis.

Características principales

- Tornillos mecanizados en titanio grado V según norma ISO-5832.
- Apriete tornillos con llave hexagonal de e/c 1,20 mm.
- Mecha apical para facilitar el inicio de roscado.
- Tornillo TX permite angular el canal del tornillo hasta 20°.

Clinic screws are defined as machined devices used for the final anchoring of the abutments, the millable implant abutment or the castable directly to the implant, while laboratory screws are the machined devices used for the temporary anchoring of castables to the replica of the implant used by the dental laboratory where the construction of dental crowns or prostheses takes place.

Key features

- Machined grade V titanium screws according to ISO-5832.
- Tightening of screws with b/f 1.20 mm hex wrench.
- Apical bit to facilitate the start of threading.
- TX screw allows the screw channel to be angled up to 20°.

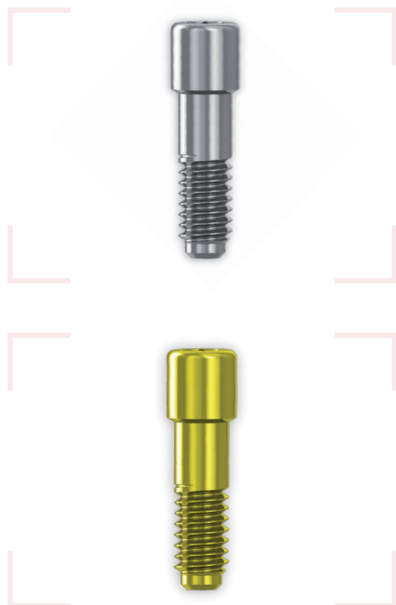

Tornillo clínica Clinic screw		
Plataforma Platform	Hex. llave (mm) Hex. wrench (mm)	Ref.
RP - WP ●●	○ 1,20 mm	KDT0C3601
	⊗ TX	KDT0C3609
Tornillo laboratorio Laboratory screw		
Plataforma Platform	Hex. llave (mm) Hex. wrench (mm)	Ref.
RP - WP ●●	○ 1,20 mm	KDT0C3602
	⊗ TX	KDT0C3610

Tornillos PME y BE gmi frontier - gmi frontier MEA and BE screws

Los tornillos clínica para PME y BE se definen como los aditamentos mecanizados utilizados para el anclaje definitivo de los aditamentos ME y BE, mientras que los tornillos de laboratorio son los aditamentos mecanizados utilizados para el anclaje provisional de los aditamentos ME y BE a la réplica durante la elaboración de la prótesis en el laboratorio.

Características principales

- Tornillos mecanizados en titanio grado V según norma ISO-5832.
- Apriete tornillos con llave hexagonal de e/c 1,20 mm y 2,00 mm.
- Tornillo TX permite angular el canal del tornillo hasta 20°.

MEA and BE clinical screws are defined as machined devices used for the final anchoring of the ME and BE abutments, while laboratory screws are the machined devices used for the temporary anchoring of ME and BE abutments to the replica during the fabrication of the prostheses in the laboratory.

Key features

- Machined grade V titanium screws according to ISO-5832.
- Tightening of screws with b/f 1.20 mm and 2.00 mm hex wrench.
- TX screw allows the screw channel to be angled up to 20°.



Tornillo PME MEA screw		
Plataforma Platform	Hex. llave (mm) Hex. wrench (mm)	Ref.
RP ●●	⊕ 1,20 mm	KDToC0056
	⊕ TX	KDToC0070
WP ●	⊕ 1,20 mm	KDToC0060
	⊕ TX	KDToC0071

Tornillo laboratorio PME MEA laboratory screw		
Plataforma Platform	Hex. llave (mm) Hex. wrench (mm)	Ref.
RP ●●	⊕ 1,20 mm	KDToC0057
	⊕ TX	KDToC0072
WP ●	⊕ 1,20 mm	KDToC0058
	⊕ TX	KDToC0073

Tornillo BE BE screw		
Plataforma Platform	Hex. llave (mm) Hex. wrench (mm)	Ref.
RP - WP ●●	⊕ 1,20 mm	KDToC4016
	⊕ TX	KDToC0074

Tornillos PME y BE gmi frontier - gmi frontier MEA and BE screws



Tornillo laboratorio BE BE laboratory screw

Plataforma Platform	Hex. llave (mm) Hex. wrench (mm)	Ref.
RP - WP ●●	⊕ 1,20 mm	KDToC4020
	⊗ TX	KDToC0075



Tornillo base BE BE base screw

Plataforma Platform	Hex. llave (mm) Hex. wrench (mm)	Altura (mm) Height (mm)	Ref.
RP - WP ●●	⊕ 2,00 mm	1,00	KDToC3605
		2,00	KDToC3606
		3,00	KDToC3607
		4,00	KDToC3608

Pares recomendados de apriete - Recommended tightening torques

Par máximo inserción implante • Implant insertion maximum torque



Apriete tapones de cierre y pilares de cicatrización • Healing abutments and cover screw tightening torque



Apriete tornillos clínica* • Clinic screw tightening torque*



Apriete pilares bola • Ball abutments tightening torque



Apriete pilares multi-estético rectos • Multi-esthetic straight abutments tightening torque



Apriete tornillos multi-estético* • Multi-esthetic screw tightening torque*



*Para los tornillos TX mismo par de apriete • *For TX screws same tightening torque

Pares recomendados de apriete - Recommended tightening torques

Apriete tornillo pilar provisional - Temporary plastic cylinder tightening torque



Apriete tornillo pilar multi-estético inclinado - Multi-esthetic angled screw tightening torque



Apriete tornillo impresión - Impression coping screw tightening torque



Apriete bases bioestéticas - Bioesthetic bases tightening torque



Apriete pilar cicatrización bioestético - Bioesthetic healing abutment tightening torque



Apriete tornillo BE* - BE screw tightening torque*



*Para los tornillos TX mismo par de apriete - *For TX screws same tightening torque

Kit quirúrgico gmi frontier/avantgard - gmi frontier/avantgard surgical kit

Los kits quirúrgicos **gmi frontier/avantgard** están formados por una caja autoclavable fabricada en resina técnica de alta resistencia, que contiene todo el material necesario para la correcta colocación de los sistemas de implantes dentales frontier y avantgard. Los componentes se encuentran dispuestos de tal manera que sea sencillo encontrar en cada momento el instrumento necesario para cada fase de la intervención.

Los kits quirúrgicos gmi se distribuyen en cajas confeccionadas en polímero técnico de alta resistencia y deben esterilizarse en autoclave de calor húmedo antes de su uso a una temperatura máxima de 134°C.

Para complementar este kit **gmi** dispone del **Kit de fresas PEAK** (*ver catálogo de instrumental*), permitiendo ampliar de forma fácil y práctica su uso para la colocación de 2 sistemas de implantes adicionales (frontier PEAK y avantgard PEAK).

gmi frontier/avantgard surgical kits consist of an autoclavable case made of high strength resin, containing all the necessary material for the correct positioning of **gmi frontier** and **avantgard** dental implant systems. The components are arranged in such a way to be easy to find in each moment and in any stage of the intervention.

gmi surgical kits are distributed in boxes made of high strength technical polymer, and must be sterilized in a moist heat autoclave before use at a maximum temperature of 134 °C.

To complement this kit, **gmi** has the **PEAK drill Kit** (*see instrumental catalogue*), allowing it to be easily expanded for the placement of 2 additional implant systems (**frontier PEAK** and **avantgard PEAK**).



KYCoF3053

Descripción - Description		Un.	Ref.
Fresa lanza	Lance-shaped drill	1	KYFoC1225
Fresa piloto ø2,50 mm	Pilot drill ø2.50 mm	1	KYFoC2250
Fresa escalonada ø2,50 / ø3,00 mm	Step drill ø2.50 / ø3.00 mm	1	KYFoC5130
Fresa escalonada ø3,00 / ø3,50 mm	Step drill ø3.00 / ø3.50 mm	1	KYFoC5135
Fresa escalonada ø3,50 / ø4,00 mm	Step drill ø3.50 / ø4.00 mm	1	KYFoC5140
Fresa escalonada ø4,00 / ø4,50 mm	Step drill ø4.00 / ø4.50 mm	1	KYFoC5145
Fresa cortical ø3,65 mm	Cortical drill ø3.65 mm	1	KYFoC4336
Fresa cortical ø3,20 mm	Cortical drill ø3.20 mm	1	KYFoC4332
Fresa cortical ø4,00 mm	Cortical drill ø4.00 mm	1	KYFoC4340
Fresa cortical ø4,50 mm	Cortical drill ø4.50 mm	1	KYFoC4345
Fresa cortical ø4,90 mm	Cortical drill ø4.90 mm	1	KYFoC4349
Fresa cortical ø5,90 mm	Cortical drill ø5.90 mm	1	KYFoC4359
Llave carraca IP	TI ratchet wrench	1	KYLoF0113
Llave-transportador HEX-2,45 mm IP corta	Short HEX-2.45 mm implant carrier TI wrench	1	KYLoF0096
Llave-transportador HEX-2,45 mm IP larga	Long HEX-2.45 mm implant carrier TI wrench	1	KYLoF0111
Llave-transportador HEX-2,45 mm CA	HEX-2.45 mm implant carrier HP wrench	1	KYLoF0091
Llave Avantgard NP/RP IP corta	Short Avantgard NP/RP TI wrench	1	KYLoF0157
Llave Avantgard NP/RP IP larga	Long Avantgard NP/RP TI wrench	1	KYLoF0162
Llave Avantgard WP IP corta	Short Avantgard WP TI wrench	1	KYLoF0168
Llave Avantgard WP IP larga	Long Avantgard WP TI wrench	1	KYLoF0169
Llave Avantgard NP/RP CA corta	Short Avantgard NP/RP HP wrench	1	KYLoF0151
Llave Avantgard WP CA corta	Short Avantgard WP HP wrench	1	KYLoF0166
Llave carraca corta HEX-1,20 mm	Short HEX-1.20 mm ratchet wrench	1	KYLoF0128
Llave carraca larga HEX-1,20 mm	Long HEX-1.20 mm ratchet wrench	1	KYLoF0129
Alargador fresas	Drill extender	1	KYLoC0023
Paralelizador ø2,00 / ø2,80 mm	Paralleling pin ø2.00 / ø2.80 mm	3	KYLoC0078
Indicador profundidad ø2,50 mm	Depth gauge ø2.50 mm	1	KYLoC0165

Kit cirugía guiada gmi frontier - gmi frontier guided surgery kit

El kit de cirugía guiada gmi frontier está formado por una caja autoclavable fabricada en resina técnica de alta resistencia, que contiene todo el material necesario para efectuar cirugías totalmente guiadas de implantes gmi frontier de $\varnothing 3,30 / \varnothing 3,75 / \varnothing 4,25$ y $\varnothing 4,75$ mm y longitudes comprendidas entre 8 y 15 mm.

Para complementar este kit gmi dispone del **Kit de fresas de cirugía guiada PEAK** (ver catálogo de instrumental), permitiendo ampliar de forma fácil y práctica su uso para la colocación de 1 sistema de implantes adicional (frontier PEAK).

gmi frontier guided surgery kit consists of an autoclavable case made of high strength resin, containing all the necessary material for performing totally guided surgeries with gmi frontier implants of $\varnothing 3.30 / \varnothing 3.75$ $\varnothing 4.25$ and $\varnothing 4.75$ mm and lengths between 8 and 15 mm.

To complement this kit, gmi has the **PEAK guided surgery drill Kit** (see *instrumental catalogue*), allowing it to be easily expanded for the placement of 1 additional implant system (frontier PEAK).



Descripción - Description		Un.	Ref.
Fresa Pin $\varnothing 1,50$ mm	Pin drill $\varnothing 1.50$ mm	1	KYFoC6060
Trepante gingival CA $\varnothing 5,10$ mm	HP gingival punch $\varnothing 5.10$ mm	1	KYFoC6066
Fresa inicial $\varnothing 2,5$ mm	Initial drill $\varnothing 2.5$ mm	1	KYFoC6101
Fresa piloto DLC $\varnothing 2,5$ L8 mm	DLC pilot drill $\varnothing 2.5$ L8 mm	1	KYFoC6201
Fresa piloto DLC $\varnothing 2,5$ L10 mm	DLC pilot drill $\varnothing 2.5$ L10 mm	1	KYFoC6202
Fresa piloto DLC $\varnothing 2,5$ L11,5 mm	DLC pilot drill $\varnothing 2.5$ L11.5 mm	1	KYFoC6203
Fresa piloto DLC $\varnothing 2,5$ L13 mm	DLC pilot drill $\varnothing 2.5$ L13 mm	1	KYFoC6204
Fresa piloto DLC $\varnothing 2,5$ L15 mm	DLC pilot drill $\varnothing 2.5$ L15 mm	1	KYFoC6205
Fresa escalonada DLC $\varnothing 2,5/\varnothing 3$ L8 mm	DLC step drill $\varnothing 2.5/\varnothing 3$ L8 mm	1	KYFoC6506
Fresa escalonada DLC $\varnothing 2,5/\varnothing 3$ L10 mm	DLC step drill $\varnothing 2.5/\varnothing 3$ L10 mm	1	KYFoC6507
Fresa escalonada DLC $\varnothing 2,5/\varnothing 3$ L11,5 mm	DLC step drill $\varnothing 2.5/\varnothing 3$ L11.5 mm	1	KYFoC6508
Fresa escalonada DLC $\varnothing 2,5/\varnothing 3$ L13 mm	DLC step drill $\varnothing 2.5/\varnothing 3$ L13 mm	1	KYFoC6509
Fresa escalonada DLC $\varnothing 2,5/\varnothing 3$ L15 mm	DLC step drill $\varnothing 2.5/\varnothing 3$ L15 mm	1	KYFoC6510
Fresa escalonada DLC $\varnothing 3/\varnothing 3,5$ L8 mm	DLC step drill $\varnothing 3/\varnothing 3.5$ L8 mm	1	KYFoC6511
Fresa escalonada DLC $\varnothing 3/\varnothing 3,5$ L10 mm	DLC step drill $\varnothing 3/\varnothing 3.5$ L10 mm	1	KYFoC6512
Fresa escalonada DLC $\varnothing 3/\varnothing 3,5$ L11,5 mm	DLC step drill $\varnothing 3/\varnothing 3.5$ L11.5 mm	1	KYFoC6513
Fresa escalonada DLC $\varnothing 3/\varnothing 3,5$ L13 mm	DLC step drill $\varnothing 3/\varnothing 3.5$ L13 mm	1	KYFoC6514
Fresa escalonada DLC $\varnothing 3/\varnothing 3,5$ L15 mm	DLC step drill $\varnothing 3/\varnothing 3.5$ L15 mm	1	KYFoC6515
Fresa escalonada DLC $\varnothing 3,5/\varnothing 4$ L8 mm	DLC step drill $\varnothing 3.5/\varnothing 4$ L8 mm	1	KYFoC6516
Fresa escalonada DLC $\varnothing 3,5/\varnothing 4$ L10 mm	DLC step drill $\varnothing 3.5/\varnothing 4$ L10 mm	1	KYFoC6517
Fresa escalonada DLC $\varnothing 3,5/\varnothing 4$ L11,5 mm	DLC step drill $\varnothing 3.5/\varnothing 4$ L11.5 mm	1	KYFoC6518
Fresa escalonada DLC $\varnothing 3,5/\varnothing 4$ L13 mm	DLC step drill $\varnothing 3.5/\varnothing 4$ L13 mm	1	KYFoC6519
Fresa escalonada DLC $\varnothing 3,5/\varnothing 4$ L15 mm	DLC step drill $\varnothing 3.5/\varnothing 4$ L15 mm	1	KYFoC6520
Fresa escalonada DLC $\varnothing 4/\varnothing 4,5$ L8 mm	DLC step drill $\varnothing 4/\varnothing 4.5$ L8 mm	1	KYFoC6521

Descripción - Description		Un.	Ref.
Fresa escalonada DLC $\varnothing 4/\varnothing 4,5$ L10 mm	DLC step drill $\varnothing 4/\varnothing 4.5$ L10 mm	1	KYFoC6522
Fresa escalonada DLC $\varnothing 4/\varnothing 4,5$ L11,5 mm	DLC step drill $\varnothing 4/\varnothing 4.5$ L11.5 mm	1	KYFoC6523
Fresa escalonada DLC $\varnothing 4/\varnothing 4,5$ L13 mm	DLC step drill $\varnothing 4/\varnothing 4.5$ L13 mm	1	KYFoC6524
Fresa cortical DLC $\varnothing 3,2$ mm	DLC cortical drill $\varnothing 3.2$ mm	1	KYFoC6401
Fresa cortical DLC $\varnothing 3,55$ mm	DLC cortical drill $\varnothing 3.55$ mm	1	KYFoC6402
Fresa cortical DLC $\varnothing 3,9$ mm	DLC cortical drill $\varnothing 3.9$ mm	1	KYFoC6403
Fresa cortical DLC $\varnothing 4,4$ mm	DLC cortical drill $\varnothing 4.4$ mm	1	KYFoC6404
Fresa cortical DLC $\varnothing 4,9$ mm	DLC cortical drill $\varnothing 4.9$ mm	1	KYFoC6405
Llave carraca corta HEX-1,20 mm	Short HEX-1.20 mm ratchet wrench	1	KYLoF0128
Adaptador HEX-4,00 mm LLCIP	HEX-4.00 mm adapter TIRW	1	KYLoC6054
Adaptador HEX-4,00 mm CA	HEX-4.00 mm adapter HP	1	KYLoC6055
Extractor transportadores	Mounters extraction wrench	1	KYLoC6115
Transportadores RP/WP + tornillo	Implant carriers RP/WP + screw	4	KYLoF6103
Llave directa RP/WP CA	Direct HP wrench RP/WP	1	KYLoF6105
Llave directa RP/WP LLCIP	Direct TIRW wrench RP/WP	1	KYLoF6106
Pin lateral férula	Lateral pin	3	KYLoC6059
Llave carraca IP	TI ratchet wrench	1	KYLoF0113
Llave transportador plana 45°	45° implant carrier manual wrench	1	KYLoC0093

*Todas las referencias se venden por separado como recambios
*All references are sold separately as spare parts

Accesorios - Accessories		Un.	Ref.
Casquillo pin lateral férula	Sleeve for lateral pin	5	KYLoF6061
Casquillo férula $\varnothing 5,10$ mm	Sleeve $\varnothing 5.10$ mm	5	KYLoF6102

Kit quirúrgico gmi PEAK - gmi PEAK surgical kit

Los kits quirúrgicos **gmi PEAK** están formados por una caja autoclavable fabricada en resina técnica de alta resistencia, que contiene todo el material necesario para la correcta colocación de los sistemas de implantes dentales frontier PEAK y avantgard PEAK. Los componentes se encuentran dispuestos de tal manera que sea sencillo encontrar en cada momento el instrumento necesario para cada fase de la intervención.

Los kits quirúrgicos gmi se distribuyen en cajas confeccionadas en polímero técnico de alta resistencia y deben esterilizarse en autoclave de calor húmedo antes de su uso a una temperatura máxima de 134°C.

Para complementar este kit **gmi** dispone del **Kit de fresas frontier/avantgard** (ver catálogo de instrumental), permitiendo ampliar de forma fácil y práctica su uso para la colocación de 2 sistemas de implantes adicionales (frontier y avantgard).

gmi PEAK surgical kit consist of an autoclavable case made of high strength resin, containing all the necessary material for the correct positioning of **gmi frontier PEAK** and **avantgard PEAK** dental implant systems. The components are arranged in such a way to be easy to find in each moment and in any stage of the intervention.

gmi surgical kits are distributed in boxes made of high strength technical polymer, and must be sterilized in a moist heat autoclave before use at a maximum temperature of 134 °C.

To complement this kit, **gmi** has the **frontier/avantgard drill Kit** (see *instrumental catalogue*), allowing it to be easily expanded for the placement of 2 additional implant systems (frontier and avantgard).



Descripción - Description		Un.	Ref.
Fresa inicial ø2,0 mm	Initial drill ø2.0 mm	1	KYFoC1401
Fresa piloto ø2,50 mm	Pilot drill ø2.50 mm	1	KYFoC2250
Fresa cónica ø3,20 mm	Conical drill ø3.20 mm	1	KYFoC7032
Fresa cónica ø3,70 mm	Conical drill ø3.70 mm	1	KYFoC7037
Fresa cónica ø4,20 mm	Conical drill ø4.20 mm	1	KYFoC7042
Fresa cortical ø3,20 mm	Cortical drill ø3.20 mm	1	KYFoC4333
Fresa cortical ø3,65 mm	Cortical drill ø3.65 mm	1	KYFoC4337
Fresa cortical ø4,15 mm	Cortical drill ø4.15 mm	1	KYFoC4342
Fresa cortical ø4,65 mm	Cortical drill ø4.65 mm	1	KYFoC4347
Fresa escalonada ø2,50 / ø2,80 mm	Step drill ø2.50 / ø2.80 mm	1	KYFoC5129
Fresa escalonada ø3,20 / ø3,65 mm	Step drill ø3.20 / 3.65 mm	1	KYFoC5137
Fresa escalonada ø3,70 / ø4,15 mm	Step drill ø3.70 / ø4.15 mm	1	KYFoC5142
Fresa escalonada ø4,15 / ø4,65 mm	Step drill ø4.15 / ø4.65 mm	1	KYFoC5147
Indicador profundidad ø2,50 mm	Depth gauge ø2.50 mm	1	KYLoC0165
Indicador profundidad cónico ø3,20 mm	Conical depth gauge ø3.20 mm	1	KYLoC0159
Indicador profundidad cónico ø3,70 mm	Conical depth gauge ø3.70 mm	1	KYLoC0160
Indicador profundidad cónico ø4,20 mm	Conical depth gauge ø4.20 mm	1	KYLoC0161
Llave carraca IP	TI ratchet wrench	1	KYLoF0113
Llave-transportador HEX - 2,45 mm CA	HEX-2.45 mm implant carrier HP wrench	1	KYLoF0091
Llave-transportador HEX - 2,45 mm IP corta	Short HEX-2.45 mm implant carrier TI wrench	1	KYLoF0096
Llave-transportador HEX - 2,45 mm IP larga	Long HEX-2.45 mm implant carrier TI wrench	1	KYLoF0111
Llave Avantgard NP/RP CA corta	Short Avantgard NP/RP HP wrench	1	KYLoF0151
Llave Avantgard NP/RP IP corta	Short Avantgard NP/RP TI wrench	1	KYLoF0157
Llave Avantgard NP/RP IP larga	Long Avantgard NP/RP TI wrench	1	KYLoF0162
Alargador fresas	Drill extender	1	KYLoC0023
Paralelizador ø2,00 / ø2,80 mm	Paralleling pin ø2.00 / ø2.80 mm	3	KYLoC0078
Llave carraca corta HEX-1,20 mm	Short HEX-1.20 mm ratchet wrench	1	KYLoF0128
Llave carraca larga HEX-1,20 mm	Long HEX-1.20 mm ratchet wrench	1	KYLoF0129

Kit cirugía guiada gmi frontier PEAK - gmi frontier PEAK guided surgery kit

El kit de cirugía guiada gmi frontier PEAK está formado por una caja autoclavable fabricada en resina técnica de alta resistencia, que contiene todo el material necesario para efectuar cirugías totalmente guiadas de implantes gmi frontier PEAK de $\varnothing 3,75$ / $\varnothing 4,25$ y $\varnothing 4,75$ mm y longitudes comprendidas entre 8 y 15 mm.

Para complementar este kit gmi dispone del **Kit de fresas de cirugía guiada frontier/avantgard** (ver catálogo de instrumental), permitiendo ampliar de forma fácil y práctica su uso para la colocación de 1 sistema de implantes adicional (frontier).

gmi frontier PEAK guided surgery kit consists of an autoclavable case made of high strength resin, containing all the necessary material for performing totally guided surgeries with gmi frontier implants of $\varnothing 3.75$, $\varnothing 4.25$ and $\varnothing 4.75$ mm and lengths between 8 and 15 mm.

To complement this kit, gmi has the **frontier/avantgard guided surgery drill Kit** (see *instrumental catalogue*), allowing it to be easily expanded for the placement of 1 additional implant system (frontier).



Descripción - Description		Un.	Ref.
Fresa Pin $\varnothing 1,50$ mm	Pin drill $\varnothing 1.50$ mm	1	KYFoC6060
Trepante gingival CA $\varnothing 5,10$ mm	HP gingival punch $\varnothing 5.10$ mm	1	KYFoC6066
Fresa inicial $\varnothing 2,5$ mm	Initial drill $\varnothing 2.5$ mm	1	KYFoC6101
Fresa piloto DLC $\varnothing 2,5$ L8 mm	DLC pilot drill $\varnothing 2.5$ L8 mm	1	KYFoC6206
Fresa piloto DLC $\varnothing 2,5$ L10 mm	DLC pilot drill $\varnothing 2.5$ L10 mm	1	KYFoC6207
Fresa piloto DLC $\varnothing 2,5$ L11,5 mm	DLC pilot drill $\varnothing 2.5$ L11.5 mm	1	KYFoC6208
Fresa piloto DLC $\varnothing 2,5$ L13 mm	DLC pilot drill $\varnothing 2.5$ L13 mm	1	KYFoC6209
Fresa piloto DLC $\varnothing 2,5$ L15 mm	DLC pilot drill $\varnothing 2.5$ L15 mm	1	KYFoC6210
Fresa escalonada DLC $\varnothing 2,5/\varnothing 2,8$ L8 mm	DLC step drill $\varnothing 2.5/\varnothing 2.8$ L8 mm	1	KYFoC6525
Fresa escalonada DLC $\varnothing 2,5/\varnothing 2,8$ L10 mm	DLC step drill $\varnothing 2.5/\varnothing 2.8$ L10 mm	1	KYFoC6526
Fresa escalonada DLC $\varnothing 2,5/\varnothing 2,8$ L11,5 mm	DLC step drill $\varnothing 2.5/\varnothing 2.8$ L11.5 mm	1	KYFoC6527
Fresa escalonada DLC $\varnothing 2,5/\varnothing 2,8$ L13 mm	DLC step drill $\varnothing 2.5/\varnothing 2.8$ L13 mm	1	KYFoC6528
Fresa escalonada DLC $\varnothing 2,5/\varnothing 2,8$ L15 mm	DLC step drill $\varnothing 2.5/\varnothing 2.8$ L15 mm	1	KYFoC6529
Fresa cónica DLC $\varnothing 3,2$ L8 mm	DLC conical drill $\varnothing 3.2$ L8 mm	1	KYFoC6706
Fresa cónica DLC $\varnothing 3,2$ L10 mm	DLC conical drill $\varnothing 3.2$ L10 mm	1	KYFoC6707
Fresa cónica DLC $\varnothing 3,2$ L11,5 mm	DLC conical drill $\varnothing 3.2$ L11.5 mm	1	KYFoC6708
Fresa cónica DLC $\varnothing 3,2$ L13 mm	DLC conical drill $\varnothing 3.2$ L13 mm	1	KYFoC6709
Fresa cónica DLC $\varnothing 3,2$ L15 mm	DLC conical drill $\varnothing 3.2$ L15 mm	1	KYFoC6710
Fresa cónica DLC $\varnothing 3,7$ L8 mm	DLC conical drill $\varnothing 3.7$ L8 mm	1	KYFoC6711
Fresa cónica DLC $\varnothing 3,7$ L10 mm	DLC conical drill $\varnothing 3.7$ L10 mm	1	KYFoC6712
Fresa cónica DLC $\varnothing 3,7$ L11,5 mm	DLC conical drill $\varnothing 3.7$ L11.5 mm	1	KYFoC6713
Fresa cónica DLC $\varnothing 3,7$ L13 mm	DLC conical drill $\varnothing 3.7$ L13 mm	1	KYFoC6714
Fresa cónica DLC $\varnothing 3,7$ L15 mm	DLC conical drill $\varnothing 3.7$ L15 mm	1	KYFoC6715
Fresa cónica DLC $\varnothing 4,2$ L8 mm	DLC conical drill $\varnothing 4.2$ L8 mm	1	KYFoC6716

Descripción - Description		Un.	Ref.
Fresa cónica DLC $\varnothing 4,2$ L10 mm	DLC conical drill $\varnothing 4.2$ L10 mm	1	KYFoC6717
Fresa cónica DLC $\varnothing 4,2$ L11,5 mm	DLC conical drill $\varnothing 4.2$ L11.5 mm	1	KYFoC6718
Fresa cónica DLC $\varnothing 4,2$ L13 mm	DLC conical drill $\varnothing 4.2$ L13 mm	1	KYFoC6719
Fresa cortical DLC $\varnothing 3,2$ mm	DLC cortical drill $\varnothing 3.2$ mm	1	KYFoC6406
Fresa cortical DLC $\varnothing 3,65$ mm	DLC cortical drill $\varnothing 3.65$ mm	1	KYFoC6407
Fresa cortical DLC $\varnothing 4,15$ mm	DLC cortical drill $\varnothing 4.15$ mm	1	KYFoC6408
Fresa cortical DLC $\varnothing 4,65$ mm	DLC cortical drill $\varnothing 4.65$ mm	1	KYFoC6409
Llave carraca corta Hex-1,20 mm	Short Hex-1.20 mm ratchet wrench	1	KYLoF0128
Adaptador Hex-4,00 mm LLCIP	Hex-4.00 mm adapter TIRW	1	KYLoC6054
Adaptador Hex-4,00 mm CA	Hex-4.00 mm adapter HP	1	KYLoC6055
Extractor transportadores	Mounters extraction wrench	1	KYLoC6115
Transportadores RP/WP + tornillo	Implant carriers RP/WP + screw	4	KYLoF6103
Llave directa RP/WP CA	Direct HP wrench RP/WP	1	KYLoF6105
Llave directa RP/WP LLCIP	Direct TIRW wrench RP/WP	1	KYLoF6106
Pin lateral férula	Lateral pin	3	KYLoC6059
Llave carraca IP	TI ratchet wrench	1	KYLoF0113
Llave transportador plana 45°	45° implant carrier manual wrench	1	KYLoC0093

*Todas las referencias se venden por separado como recambios
 *All references are sold separately as spare parts

Accesorios - Accessories		Un.	Ref.
Casquillo pin lateral férula	Sleeve for lateral pin	5	KYLoF6061
Casquillo férula $\varnothing 5,10$ mm	Sleeve $\varnothing 5.10$ mm	5	KYLoF6102

Especificaciones técnicas - Technical specifications

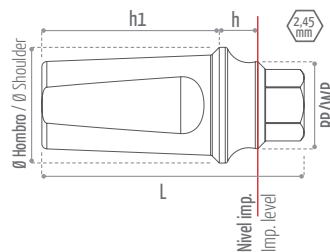
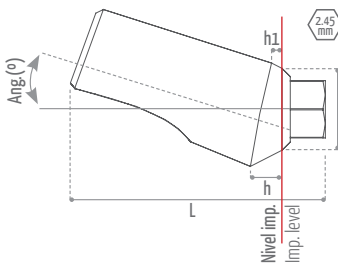
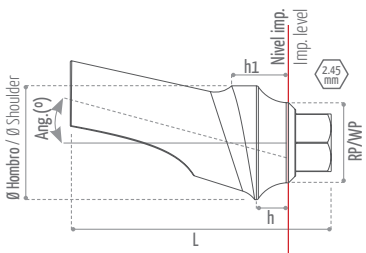
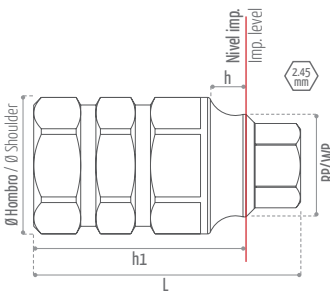
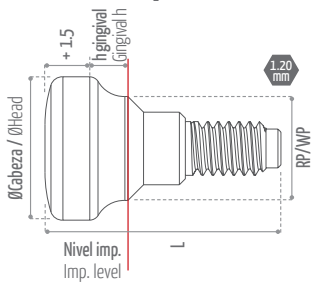
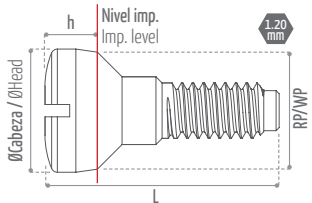

Pilares de cicatrización - Healing abutments (mm)

Referencia - Reference	L	h	h gingival	Ø Cabeza - Ø Head	Plataforma - Platform
KDPoC3601	7,60	2,00	1,00	Ø 4,00	RP
KDPoC3602	8,60	3,00	2,00		
KDPoC3603	9,60	4,00	3,00		
KDPoC3604	10,60	5,00	4,00		
KDPoC3605	7,60	2,00	1,00	Ø 5,00	WP
KDPoC3606	8,60	3,00	2,00		
KDPoC3607	9,60	4,00	3,00		
KDPoC3608	10,60	5,00	4,00		
KDPoC3609	8,60	3,00	1,50	Ø 5,00	RP
KDPoC3617	7,90	3,00	1,50		
KDPoC3618	8,90	4,00	2,50		
KDPoC3619	9,90	5,00	3,50		
KDPoC3620	10,90	6,00	4,50	Ø 6,00	WP
KDPoC3613	8,60	3,00	1,50		
KDPoC3621	7,90	3,00	1,50		
KDPoC3622	8,90	4,00	2,50		
KDPoC3623	9,90	5,00	3,50	Ø 6,00	WP
KDPoC3624	10,90	6,00	4,50		

Pilares fresables - Millable-implant abutments (mm)

Referencia - Reference	L	h	h1	Ø Hombro - Ø Shoulder	Plataforma - Platform
KDBoF3603	8,80	1,40	7,00	Ø 4,50	RP
KDBoF3602	8,70	1,40	7,00	Ø 4,50	WP

Pilares inclinados estéticos - Esthetic angled abutments (mm)

Referencia - Reference	L	h	h1	Ang. (°)	Ø Hombro - Ø Shoulder	Plataforma - Platform
KDMoF3634	11,00	1,30	2,50	15°	Ø 4,80	RP
KDMoF3654	13,00	3,30	4,50	15°		
KDMoF3635	11,00	1,30	2,50	20°		
KDMoF3656	13,00	3,30	4,50	20°		
KDMoF3636	11,00	1,30	2,50	15°	Ø 5,50	WP
KDMoF3655	13,00	3,30	4,50	15°		
KDMoF3637	11,00	1,30	2,50	20°		
KDMoF3657	13,00	3,30	4,50	20°		

Pilares inclinados - Angled abutments (mm)

Referencia - Reference	L	h	h1	Ang. (°)	Plataforma - Platform
KDMoF3613	10,80	1,50	0,50	20°	RP
KDMoF3614	10,80	1,00	0,50	20°	WP

Pilares rectos - Straight abutments (mm)

Referencia - Reference	L	h	h1	Ø Hombro - Ø Shoulder	Plataforma - Platform
KDMoF3628	10,20	1,50	6,90	Ø 4,50	RP
KDMoF3629	11,20	2,50	6,90		
KDMoF3630	12,20	3,50	6,90		
KDMoF3631	10,20	1,50	6,90	Ø 5,50	WP
KDMoF3632	11,20	2,50	6,90		
KDMoF3633	12,20	3,50	6,90		

Especificaciones técnicas - Technical specifications

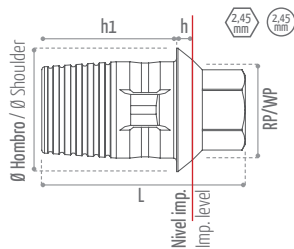

Base de titanio - Titanium base (mm)							
Referencia - Reference	L	h	h1	Ø Hombro - Ø Shoulder	Conexión - Connection	Plataforma - Platform	
KDMOF3615	7,10	0,65	4,70	Ø 4,30	Anti-rotatoria - Non-rotary	RP	
KDMOF3616	6,60	0,65	4,70	Ø 4,30	Rotatoria - Rotary		
KDMOF3638	8,00	1,50	4,70	Ø 4,30	Anti-rotatoria - Non-rotary		
KDMOF3640	7,50	1,50	4,70	Ø 4,30	Rotatoria - Rotary		
KDMOF3639	9,50	3,00	4,70	Ø 4,30	Anti-rotatoria - Non-rotary		
KDMOF3641	9,00	3,00	4,70	Ø 4,30	Rotatoria - Rotary		
KDMOF3650	11,00	4,50	4,70	Ø 4,30	Anti-rotatoria - Non-rotary		
KDMOF3651	10,50	4,50	4,70	Ø 4,30	Rotatoria - Rotary		
KDMOF3617	7,10	0,65	4,70	Ø 5,30	Anti-rotatoria - Non-rotary		WP
KDMOF3618	6,50	0,65	4,70	Ø 5,30	Rotatoria - Rotary		
KDMOF3642	8,00	1,50	4,70	Ø 5,30	Anti-rotatoria - Non-rotary		
KDMOF3644	7,35	1,50	4,70	Ø 5,30	Rotatoria - Rotary		
KDMOF3643	9,50	3,00	4,70	Ø 5,30	Anti-rotatoria - Non-rotary		
KDMOF3645	8,85	3,00	4,70	Ø 5,30	Rotatoria - Rotary		
KDMOF3652	11	4,45	4,70	Ø 5,30	Anti-rotatoria - Non-rotary		
KDMOF3653	10,4	4,50	4,70	Ø 5,30	Rotatoria - Rotary		

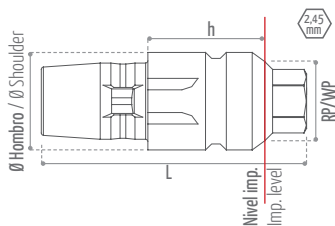

Pilar escaneado - Scan abutment (mm)				
Referencia - Reference	L	h	Ø Hombro - Ø Shoulder	Plataforma - Platform
KDIOF3601	11,70	5,30	Ø 4,30	RP
KDIOF3602	11,70	5,30	Ø 5,30	WP

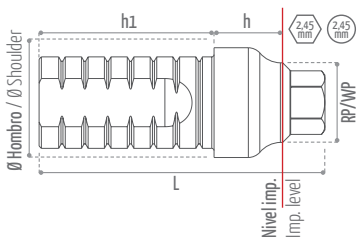

Pilares provisionales - Temporary cylinders (mm)						
Referencia - Reference	L	h	h1	Ø Hombro - Ø Shoulder	Conexión - Connection	Plataforma - Platform
KDHO3605	12,50	3,00	7,65	Ø 4,80	Anti-rotatoria - Non-rotary	RP
KDHO3607	12,50	3,00	7,50	Ø 4,80	Rotatoria - Rotary	
KDHO3606	12,50	3,00	7,60	Ø 5,80	Anti-rotatoria - Non-rotary	WP
KDHO3608	12,50	3,00	7,60	Ø 5,80	Rotatoria - Rotary	

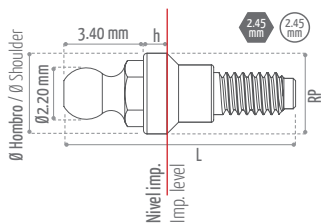

Pilares bola - Ball abutments (mm)				
Referencia - Reference	L	h	Ø Hombro - Ø Shoulder	Plataforma - Platform
KDFO3609	9,90	1,00	Ø 3,45	RP
KDFO3610	10,90	2,00		
KDFO3611	11,90	3,00		
KDFO3612	12,90	4,00		

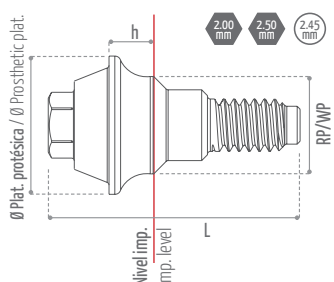

Pilares multi-estético rectos - Multi-esthetic straight abutments (mm)				
Referencia - Reference	L	h	Ø Plat. protésica - Ø Prosthetic plat.	Plataforma - Platform
KDGO3601	8,10	1,00	Ø 4,80	RP
KDGO3620	8,70	1,50		
KDGO3621	9,70	2,50		
KDGO3622	10,70	3,50		
KDGO3623	11,70	4,50		
KDGO3605	8,00	1,00		
KDGO3624	8,60	1,50	Ø 6,00	WP
KDGO3625	9,60	2,50		
KDGO3626	10,60	3,50		
KDGO3627	11,60	4,50		

Especificaciones técnicas - Technical specifications

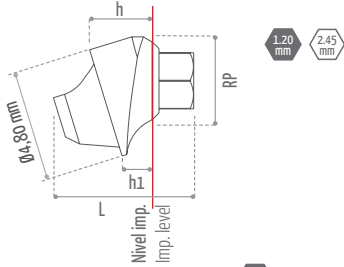

Pilares multi-estético inclinados - Multi-esthetic angled abutments (mm)					
Referencia - Reference	Ang. (°)	L	h	h1	Plataforma - Platform
KDGoF3609	17°	6,20	2,50	1,30	RP
KDGoF3610	17°	7,20	3,50	2,40	
KDGoF3611	30°	7,20	4,00	1,80	

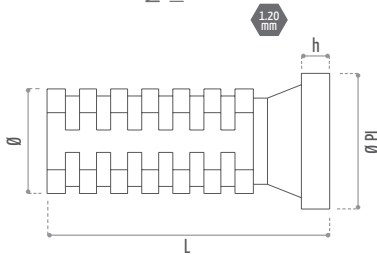

Cilindros provisionales PME - Temporary cylinder MEA (mm)				
Referencia - Reference	L	h	Ø	Ø PL
KDGof0028	10,00	1,00	3,70	4,80
KDGof0029	10,00	1,00	4,90	6,00

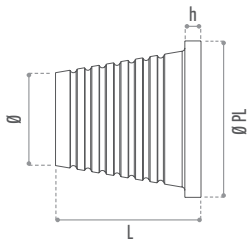

Base titanio PME - Titanium base MEA (mm)				
Referencia - Reference	L	h	Ø	Ø PL
KDGof0035	4,50	0,50	2,85	4,80
KDGof0036	4,50	0,50	3,95	6,00

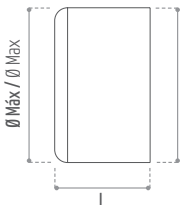

Pilares cicatrización PME - Healing abutments MEA (mm)			
Referencia - Reference	L	Ø Máx - Ø Max	Ø PL
KDPof0035	3,80	4,80	4,80
KDPof0037	3,80	6,00	4,80
KDPof0036	3,80	6,00	6,00

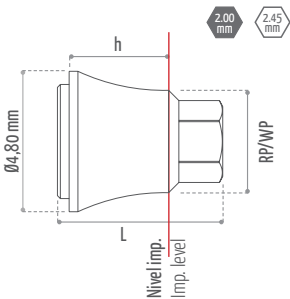

Bases bioestéticas - Bioesthetic bases (mm)			
Referencia - Reference	L	h	Plataforma - Platform
KDGoF3612	3,65	1,4	RP
KDGoF3613	4,65	2,4	
KDGoF3614	5,65	3,4	
KDGoF3615	6,65	4,4	WP
KDGoF3616	3,65	1,4	
KDGoF3617	4,65	2,4	
KDGoF3618	5,65	3,4	
KDGoF3619	6,65	4,4	

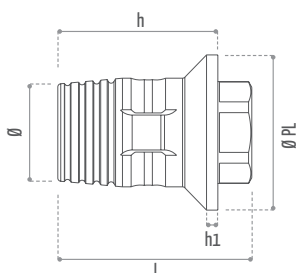

Base titanio BE - BE titanium base (mm)					
Referencia - Reference	L	h	h1	Ø	Ø PL
KDGoF4018	6,00	4,95	0,35	3,00	4,80

Especificaciones técnicas - Technical specifications

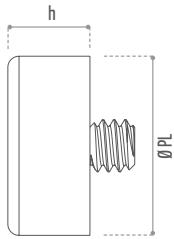

Pilar cicatrización BE - BE healing abutment (mm)		
Referencia - Reference	h	Ø PL
KDPoF0038	2,20	4,80

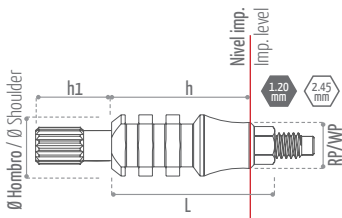

Tomas impresión cubeta abierta (CA) - Open tray (OT) impression coping (mm)						
Referencia - Reference	L	h	h1	Ø Hombro - Ø Shoulder	Tornillo - Screw	Plataforma - Platform
KDSOF3608	12,00	10,20	---	Ø 4,50	Corto - Short	RP
KDSOF3609	12,00	10,20	5,00	Ø 4,50	Largo - Long	RP
KDSOF3610	12,00	10,20	---	Ø 5,50	Corto - Short	WP
KDSOF3611	12,00	10,20	5,00	Ø 5,50	Largo - Long	WP

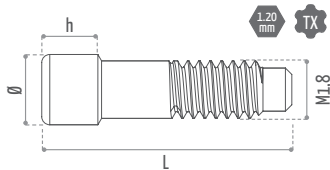

Tornillo clínica - Clinic screw (mm)				
Referencia - Reference	L	h	Ø	Plataforma - Platform
⊕ KDToc3601	7,80	2,20	2,30	RP - WP
⊕ KDToc3609	6,60	1,50	2,20	RP - WP

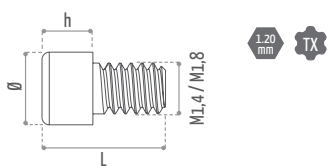

Tornillo PME - MEA screw (mm)				
Referencia - Reference	L	h	Ø	Plataforma - Platform
⊕ KDToc0056	3,40	1,40	2,00	RP
⊕ KDToc0070	3,40	1,40	2,10	RP
⊕ KDToc0060	3,40	1,40	2,80	WP
⊕ KDToc0071	3,40	1,40	2,80	WP

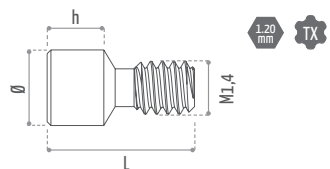

Tornillo BE - BE screw (mm)				
Referencia - Reference	L	h	Ø	Plataforma - Platform
⊕ KDToc4016	3,90	1,50	2,00	RP - WP
⊕ KDToc0074	3,90	1,50	2,10	RP - WP

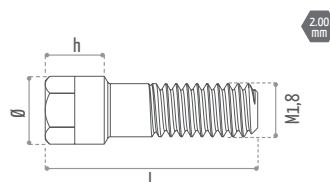

Tornillo base BE - BE base screw (mm)				
Referencia - Reference	L	h	Ø	Plataforma - Platform
KDToc3605	7,20	2,00	2,30	RP - WP
KDToc3606	8,00	2,80		
KDToc3607	9,00	3,80		
KDToc3608	10,00	4,80		

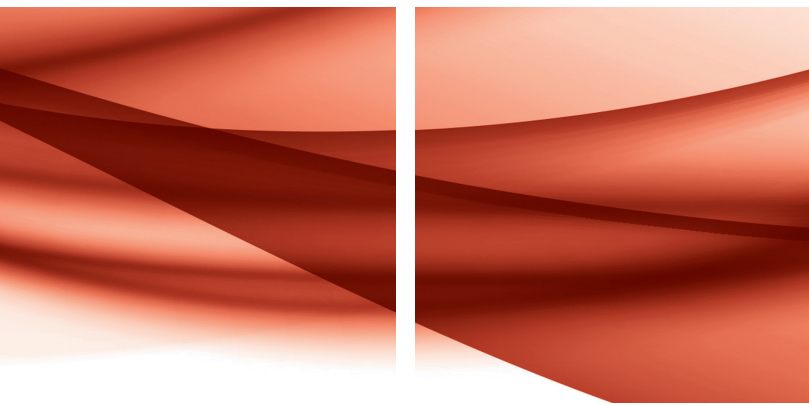

 **GMI**
Dental Implantology, S.L.
Pol. Ind. El Segre
C/ Enginyer Mies 705-B
25191 Lleida (SPAIN)
Tel. (+34) 973 184 350
info@gmidental.com
www.gmidental.com



Distribuido por:
Distributed by:

