

GMI FRONTIER
implant system

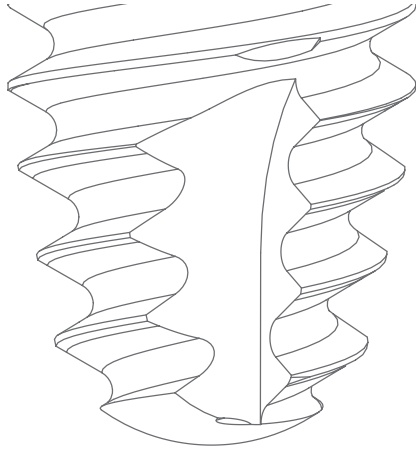

**Surgical
procedures
guide**

ABOUT THIS MANUAL

This surgical procedures guide or surgical manual for the **GMI frontier** implant system is designed solely to provide instructions for using **GMI frontier** products, and is not intended to describe diagnosis methods or procedures, treatment planning or the location of the implants, nor does it replace clinical training or clinical judgement about the needs of each patient. **GMI** recommends appropriate and specific training as a prerequisite for the placement of implants and the associated treatment.

The methods illustrated and described in this manual reflect an ideal patient with the bone and soft tissue required for the placement of an implant. We do not intent to cover the wide range of adverse conditions that may negatively affect the success of the surgery or rehabilitation. **The experience and judgement of the clinician in relation to any particular case must always be above the recommendations made in this or any other GMI manual.**

Rx only - Caution: Federal (USA) law restricts these devices to sale by, or on the order, of a dentist or physician.

TABLE OF CONTENTS



INTRODUCTION

Description of the implant system	4
GMI frontier surgical kit	7
Optional surgical instruments	10

SURGICAL PROTOCOL (STEP 1)

Bone bed drilling	13
GMI frontier drilling sequences	16
Implant insertion	18

SURGICAL PROTOCOL (STEP 2)

Healing abutments	22
Healing abutments for multi-esthetic abutments	23
Healing abutments for bioesthetic bases	26



► INDICATIONS

GMI frontier Dental Implant System model is intended to be used for surgical placement in upper or lower jaw to provide a support for prosthetic devices such as artificial teeth, in order to restore the patient's chewing function. These products should only be used by trained professionals.

► KEY FEATURES

CRESTAL BONE PRESERVATION

Cortical micro-threading increases the surface of bone-implant contact, thus improving load distribution and reducing crestal bone resorption.



INTEGRATED PLATFORM SWITCHING

The diameter of the abutment is less than the diameter of the implant platform facilitating the creation of space for soft biological tissue sealing.

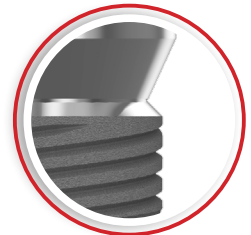

HIGH PRIMARY STABILITY

The thread of the implant body enables obtaining a good primary stability in all bone densities.



STABLE AND ACCURATE CONNECTION

The internal hex 1.50 mm deep and 45 degree cone create a rigid connection and a stable biologic seal.

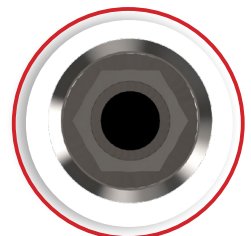

EXCELLENT BIOLOGICAL RESPONSE

Implant made of pure grade 4 titanium with an exclusive ADS surface treatment that generates an excellent biological response promoting osseointegration of the implant even in the most complicated cases.



▶ IMPLANT RANGE

The **GMI frontier** implant range consists of implants available in five different diameters and different lengths to suit all clinical situations:

Ø BODY	Ø3.30 mm	Ø3.75 mm	Ø4.25 mm	Ø4.75 mm	Ø5.75 mm
COLOUR	●	●	●	●	●
Ø CORTICAL	Ø3.50 mm	Ø4.00 mm	Ø4.50 mm	Ø5.00 mm	Ø6.00 mm
PLATFORM	RP	RP	RP	WP	WP
LENGTHS	8 to 15 mm	8 to 17 mm	6.5 to 17 mm	6.5 to 13 mm	6.5 to 13 mm

▶ USAGE RECOMMENDATIONS

Before starting any type of surgical procedure with **GMI** implants follow the recommendations below:

- Plan the treatment using radiological templates or digital planning.
- Observe the distances between the implant and tooth adjacent to and between adjacent implants.
- Read the instructions for use at www.gmidental.com/ifu.
- Become familiar with all instrumental parts and their usage.
- Read the specific drilling sequences for each implant diameter.
- Clean and properly sterilize surgical kit following the instructions.

GMI frontier implants have been designed to be used as a unitary restoration according to the following occlusal diagram:

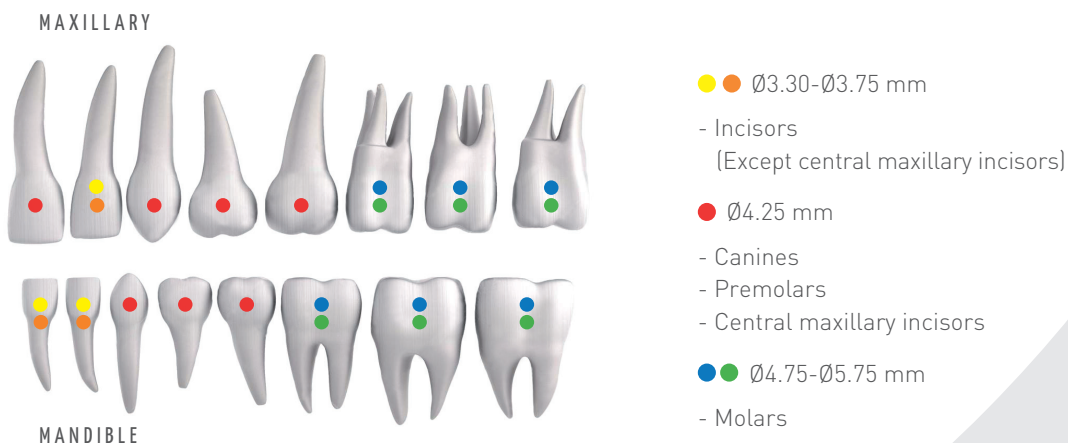

FRONTIER

▶ IMPLANT SYSTEM LABELLING DESCRIPTION

In the chart are detailed all the symbols that appear on the implant system labelling and packaging and their corresponding description:

1		Reference
2		Batch code
3		Use-by-date
4		Unique device identifier
5		Medical device
6		Manufacturer
7		Sterilized using gamma radiation
8		Single sterile barrier system with protective packaging outside
9		Single use only
10		Do not use if packaging is damaged or opened
11		Do not resterilize
12		MR Conditional: Items do not pose any known hazards in a specific MR environment with specific conditions of use
13		Manufacturing date
14		Electronic instructions for use gmidental.com/IFU
15		European conformity mark
16		Sale by or on the order of a licensed dentist
17		Non-sterile

Implant label

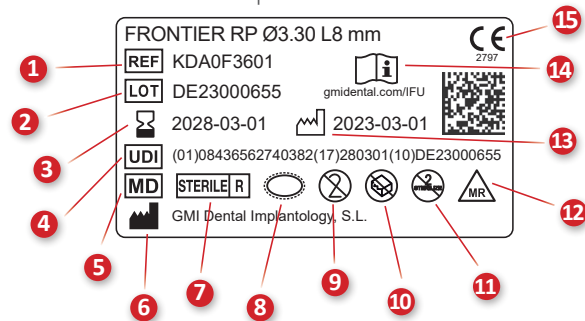

Attachments label

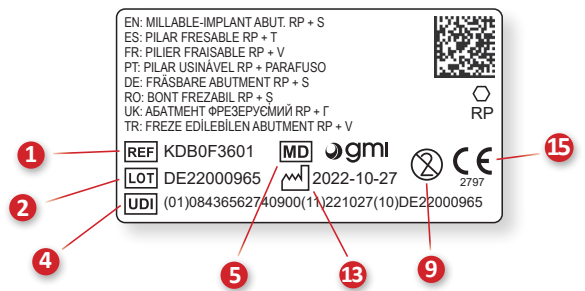

Connection and platform



FRONTIER

The **GMI frontier surgical kit** consists of a box of autoclavable technical plastic which includes all the necessary components for preparing the bone bed and placing the implant.

DENTAL DRILLS



- **Lanced drill:** Enables marking the beginning of the osteotomy and performing the initial drilling of the cortical plate.
- **Pilot drill:** Enables starting the osteotomy by performing a drilling of $\varnothing 2.50$ mm to the desired depth. To control the depth the high contrast depth markings can be used or the GMI drill stops.
- **Step drill:** Gradually widens the osteotomy allowing implant placement in dense bone. Final drill for type I / II bones.
- **Cortical drill:** It allows widening the cortical part of the osteotomy to avoid overcompression of the cortex. Final drill for type II / III bones.



Color coding: According to implant diameter and bone density.

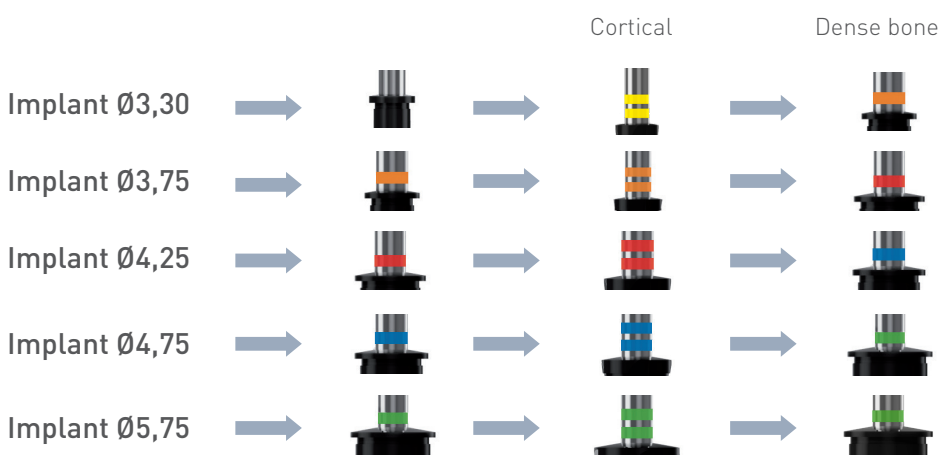

PARALLELING PINS



Once inserted into the bone bed, it enables checking the parallelism between the preparation and other adjacent structures or implants. It can be used on both sides depending on the diameter of the drilling: on one side it measures $\varnothing 2.00$ mm and on the other side $\varnothing 2.80$ mm.



DEPTH GAUGE



Once inserted into the osteotomy it enables checking the depth of the preparation to adapt it to the length of the implant to be placed. The marks of the implant lengths are included (L6.5/L8/L10/L11.5/L13/L15/L17).



TIP EXTENDER



In cases where it is necessary it increases the length of the components with HP connections by 15 mm.



HEX-1.20 HEXAGONAL WRENCHES



Once introduced in the hexagon socket part, it enables screwing and loosening the cover screws, the healing abutments and clinical screws. They are designed both for manual use as well as coupled to the TI ratchet wrench. They are available in long (28 mm) and short (21 mm) versions.



FRONTIER

CARRIER WRENCHES



Once inserted correctly in the carrier connection it enables removing the implant from the container, putting it into the mouth, starting the thread manually in the bone bed and carrying out the final insertion with the TI ratchet wrench. They are available in short and long versions and have depth and orientation markings as a reference. There is also a version with HP connection.



TI RATCHET WRENCH

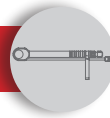

Ratchet wrench with torque indicator (TI) allows controlling the insertion torque when screwing the implant during the surgical procedure, and accurately applying torque on the attachments of the prosthetic phase. See instructions for reference.



OPTIONAL SURGICAL INSTRUMENTS



This section describes the optional surgical instruments used only in specific cases and that are not part of the **GMI frontier** surgical kit.

GINGIVAL PUNCH

Enables making circular incisions directly into the soft tissue, avoiding having to do the flap technique to discover the implant bone bed. They are available in cut diameters of $\varnothing 5.00$ and $\varnothing 6.00$ mm.



THREAD FORMERS

Enables working the implant thread in the bone bed once the preparation is completed to facilitate threading the implants in type I and type II dense bone type. They are available separately for each implant diameter and in a kit that includes all the **frontier** system thread formers.



HP ADAPTOR WRENCH

Adapter that allows using all the wrenches with a HP connection (hand-piece) manually or coupled to the TI ratchet wrench.



TOPES PROFUNDIDAD PARA FRESAS

For controlling in a simple, precise and safe way the drilling depth of the bone bed depending on the length of the implant to be placed. They are available in three diameters depending on the diameter of the drill to be used: L1 (for drilling from $\varnothing 2.0$ mm and $\varnothing 3.0$ mm) L2 (for drilling from $\varnothing 3.2$ mm and $\varnothing 4.3$ mm) and L3 (for drilling between $\varnothing 4.5$ mm and $\varnothing 5.4$ mm) and for implant lengths between 6.5 and 15 mm. They are available separately or in a kit that includes all the stops.



IMPLANT EXTRACTOR

Once introduced into the internal thread of the implant, it enables removing a failed implant from the bone bed, preventing the use of trephines and thus preserving a greater amount of bone. They are designed to be used manually with the TI torque wrench.



FRONT

SURGICAL PROTOCOL (step 1)

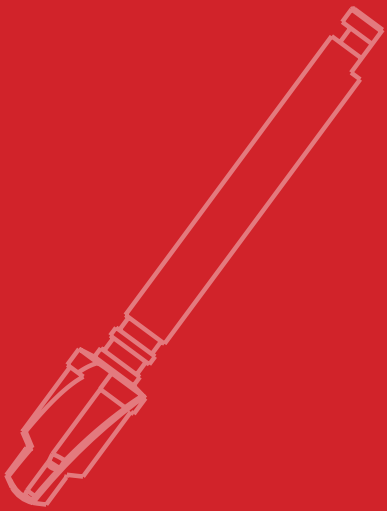

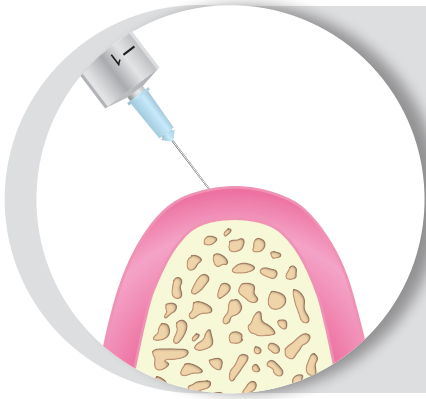

1. Anaesthetize

Apply infiltrative anaesthesia in soft tissues following standard clinical procedures.

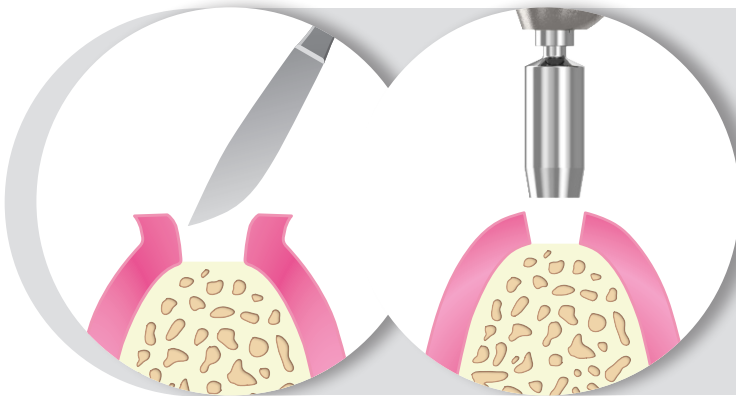

2. Perform soft tissue incision

Identify the anatomical area to respect and uncover the bone in the implant placement by making a crestal incision with a scalpel if use the flap technique, or using a manual gingival punch for flapless technique (Ref. KYLOF0024 or KYLOF0082) or with a HP connection (Ref. KYLOC0074 or KYLOC0075).

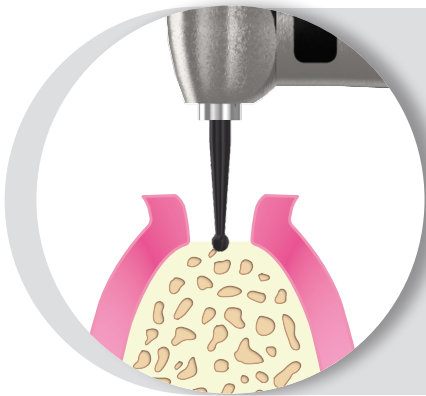

3. Mark osteotomy beginning (optional)

Set the engine speed between 1200-1500 rpm, and use the ball drill (Ref. KYCOC1502) to make a small initial mark on the bone crest. Use plenty of external cooling with saline solution at a low temperature.

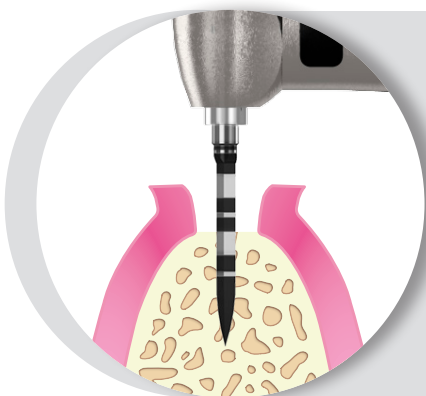

4. Mark osteotomy beginning

Set the engine speed between 900-1200 rpm, depending on the bone density, and use the lance-shaped drill (Ref. KYF0C1225) to mark the bone and start the osteotomy. Use plenty of external cooling with saline solution at a low temperature.

FRONT

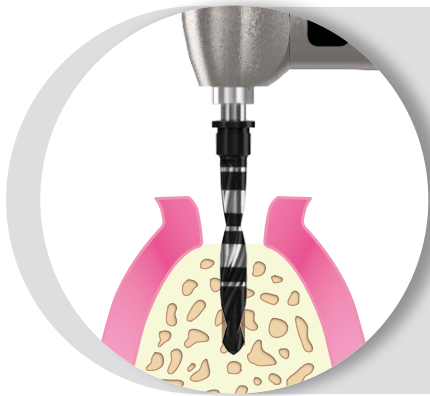

5(a). Perform initial drilling

Set the engine speed between 900-1200 rpm, depending on the bone density, and use the $\varnothing 2.50$ mm pilot drill (Ref. KYFOC2250) to determine the angle and depth of the osteotomy. Use plenty of external cooling with saline solution at a low temperature.

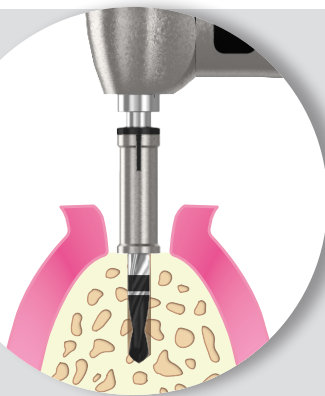

5(b). Drill depth control

To control the depth of the osteotomy use the high contrast visual markers on the drill or the appropriate stop. For the reference see the **GMI** stop instructions for use.

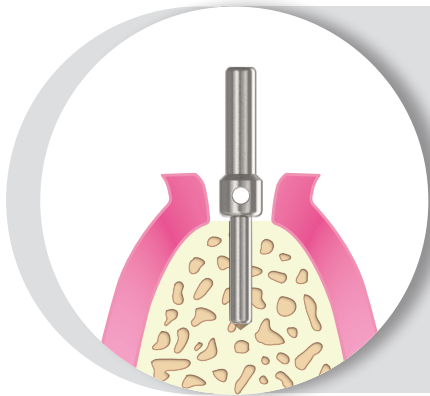

6. Check position and parallelism

Insert the $\varnothing 2.00$ mm diameter parallelizing pin on the side (Ref. KYLOC0078) to check the position and angle of the osteotomy.

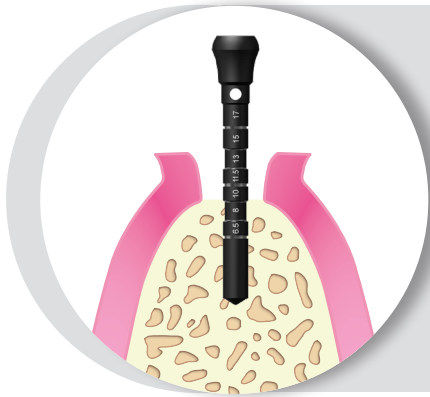

7. Check depth with the $\varnothing 2.00$ mm gauge

Insert the $\varnothing 2.50$ mm depth gauge (Ref. KYLOC0165) to check the depth of the osteotomy.

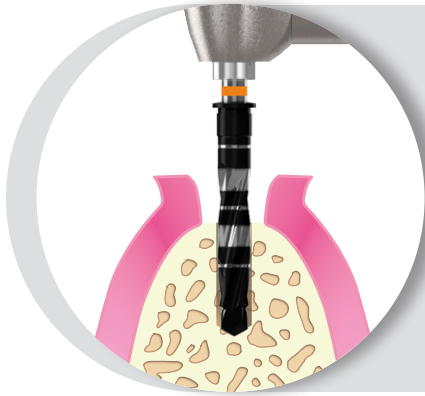

8(a). Perform osteotomy widening

Set the engine speed between 400 and 700 rpm, depending on the bone density, and use Ø3.00 to Ø5.10 mm drills (Ref. KYC0C51XX) to progressively widen the osteotomy. Use the appropriate drilling sequence for each implant diameter (see next section for reference). Use plenty of external cooling with saline solution at a low temperature.



8(b). Drill depth control

To control the depth of the osteotomy use the high contrast visual markers on the drill or the appropriate stop. For the reference see the **GMI** stop instructions for use.

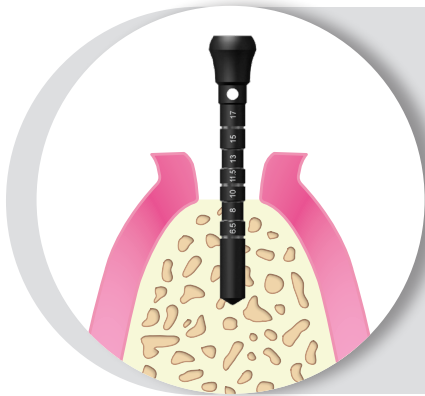

9. Check depth

Insert the depth gauge (Ref. KYL0C0165) to check the depth of the osteotomy to make the final drilling for each implant diameter. Increase the depth of the osteotomy in case of not having the necessary depth.

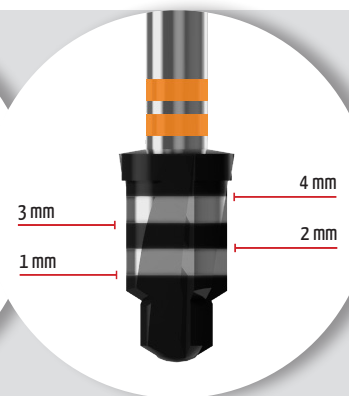
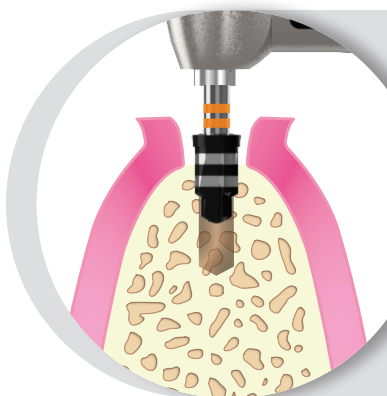

10. Countersink the cortical (only for bone type II/ III)

Set the engine speed between 200 and 400 rpm depending on the bone density, and use the corresponding cortical drill for the implant to place (see colour coding) to cross the cortical. Use the depth marks as a reference.

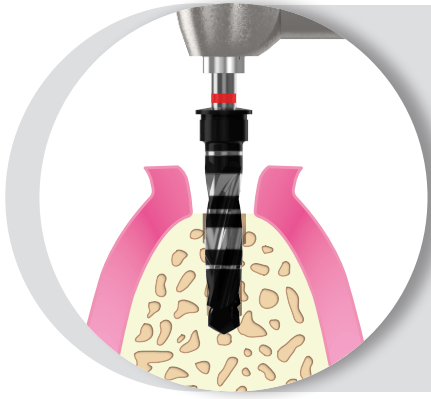

11. Perform osteotomy widening (only for bone I)

In case of dense bones (Type I and II) use the suitable step drill (Ref. KYF0C51XX) to widen the osteotomy.

DRILLING SEQUENCES



The **gmi frontier** implant system drilling sequences and the recommended conditions for use are as follows:

- **Lance-shaped drill:** 1200-1500 rpm.
- **Pilot drill:** 700-900 rpm.
- **Step drills:**
 - Ø3.00 – Ø3.50 mm -----> 400-700 rpm.
 - Ø4.00 - Ø5.10 mm -----> 400-600 rpm.
- **Cortical drills:** 200-400 rpm.

▶ FRONTIER IMPLANT SEQUENCE Ø3.30 mm

- 1- Lance-shaped drill (KYF0C1225)
- 2- Pilot drill Ø2.50 (KYF0C2250)
- 3- Cortical drill Ø3.65 (KYF0C4336)
- 4- Step drill Ø2.50/Ø3.00 (KYF0C5130)

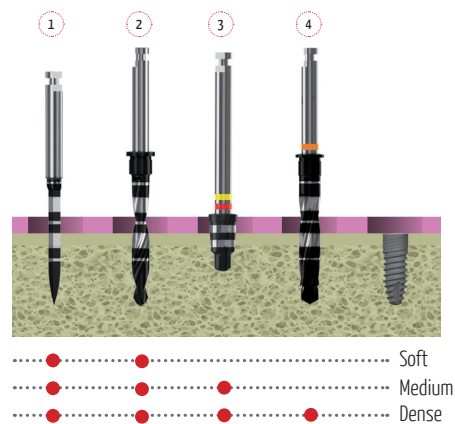

▶ FRONTIER IMPLANT SEQUENCE Ø3.75 mm

- 1- Lance-shaped drill (KYF0C1225)
- 2- Pilot drill Ø2.50 (KYF0C2250)
- 3- Step drill Ø2.50/Ø3.00 (KYF0C5130)
- 4- Cortical drill Ø4.00 (KYF0C4340)
- 5- Step drill Ø3.00/Ø3.50 mm (KYF0C5135)

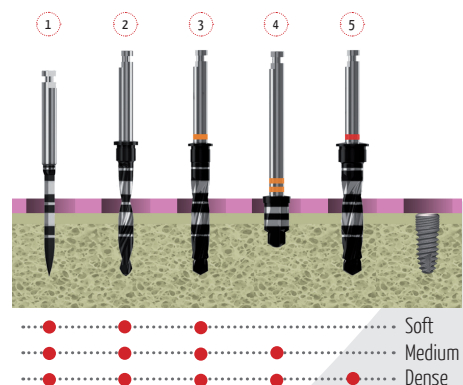

FRONTIER

▶ FRONTIER IMPLANT SEQUENCE Ø4.25 mm

- 1- Lance-shaped drill (KYF0C1225)
- 2- Pilot drill Ø2.50 (KYF0C2250)
- 3- Step drill Ø2.50/Ø3.00 (KYF0C5130)
- 4- Step drill Ø3.00/Ø3.50 (KYF0C5135)
- 5- Cortical drill Ø4.50 (KYF0C4345)
- 6- Step drill Ø3.50/Ø4.00 mm (KYF0C5140)

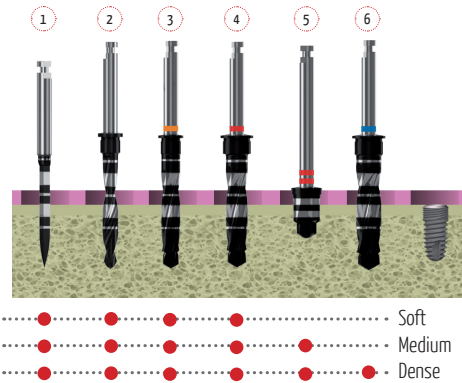

▶ FRONTIER IMPLANT SEQUENCE Ø4.75 mm

- 1- Lance-shaped drill (KYF0C1225)
- 2- Pilot drill Ø2.50 (KYF0C2250)
- 3- Step drill Ø2.50/Ø3.00 (KYF0C5130)
- 4- Step drill Ø3.00/Ø3.50 (KYF0C5135)
- 5- Step drill Ø3.50/Ø4.00 (KYF0C5140)
- 6- Cortical drill Ø4.90 (KYF0C4349)
- 7- Step drill Ø4.00/Ø4.50 mm (KYF0C5145)

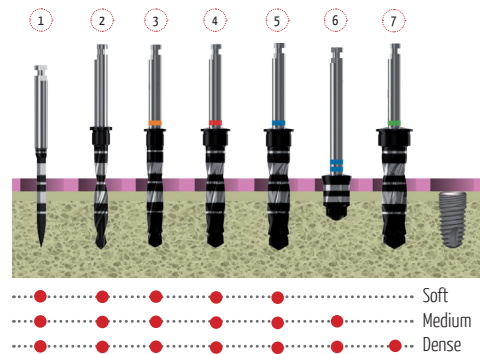

▶ FRONTIER IMPLANT SEQUENCE Ø5.75 mm

- 1- Lance-shaped drill (KYF0C1225)
- 2- Pilot drill Ø2.50 (KYF0C2250)
- 3- Step drill Ø2.50/Ø3.00 (KYF0C5130)
- 4- Step drill Ø3.00/Ø3.50 (KYF0C5135)
- 5- Step drill Ø3.50/Ø4.00 (KYF0C5140)
- 6- Step drill Ø4.00/Ø4.50 (KYF0C5145)
- 7- Cortical drill Ø5.90 (KYF0C4359)
- 8- Step drill Ø4.00/Ø5.10 (KYF0C5151)

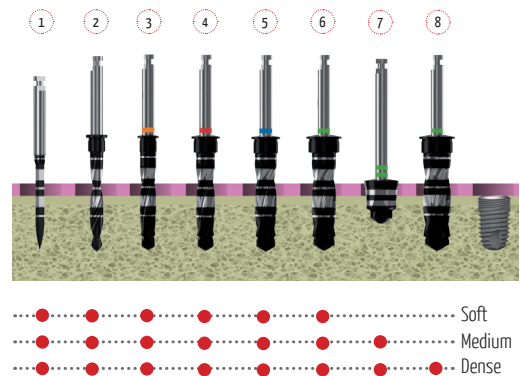

NOTE: GMI's recommended process cannot replace the judgement and experience of the surgeon.

IMPLANT INSERTION



1. Initial check

Ensure that the diameter and length indicator sticker, located at the bottom of the outer case, matches the diameter and length of the implant to be placed. Check the expiry date that appears in the front label is later than the date of use.



2. Open outer package

Open the tab on the box and remove the secondary packaging and adhesive labels identifying the product. Check the integrity of the secondary packaging. If some type of product manipulation is noticed please discard it.



3. Open the secondary container and remove the primary container

Check the security seal on the secondary container and discard the implant if there are signs of it having been tampered. Turn the cap anti-clockwise to break the seal. Remove the primary container and avoid hitting it against a hard surface.



4. Open primary packaging cap

Hold the primary container vertically with the cap upwards and open the cap with a lateral movement. Store the primary cap vertically for the last phase of surgery because it contains the sealing cap inside.

FRONTIER



5. Insert the key into the implant

Keeping the container upright, insert the **frontier** short or long wrench (Ref. KYL0F0096 or KYL0F0111) inside the implant, taking into account correctly orienting the hex wrench and implant until it stops.

Important: Ensure that the wrench is fully inserted into the implant before removing it from the internal support.



6. Extract implant from the primary container

Once the wrench is properly inserted in the implant gently remove the entire set as vertically as possible, preventing where possible the implant from rubbing the titanium support.



7. Implant insertion

Perform the initial implant insertion manually in the bone bed prepared in the previous step.

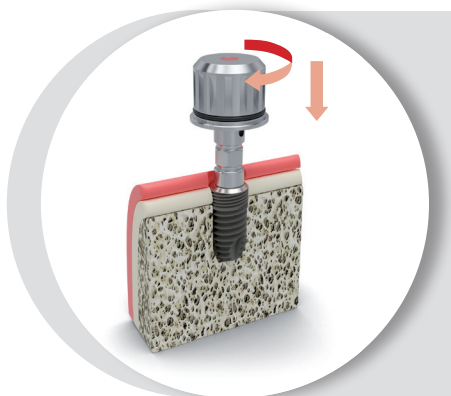

8. Finish inserting the implant

Finish inserting the implant with the TI torque ratchet wrench until it is placed on the crestal level, applying a torque of **35 N•cm**. With the aid of the reference marks of the insertion wrench guide one side of the hexagon of the implant towards the face, and measure the thickness of the soft tissue with depth markings for the subsequent selection of the healing abutment.

Important: Do not exceed 60 N•cm during the insertion of the implant to prevent the connection from deforming.

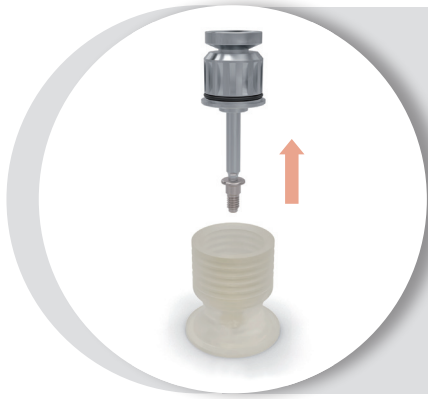

9. Extract cover screw

Insert the HEX-1.20 mm wrench (Ref. KYLOF0128) in the cover screw hexagon and lightly press down. Slightly turn anti-clockwise to remove the wrench-cap from the inner housing of the primary cap.

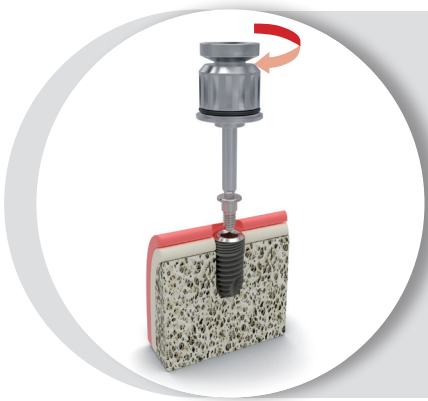

10. Place the closing cap in the implant

Ensure that the connection is free of bone debris or soft tissue. Using the HEX-1.20 mm wrench (Ref. KYLOF0128) manually thread the cover screw to the implant, applying a torque of **15 N·cm**.



11. Suture the incision

Verify that the implant is in the correct position and that the cover screw sits perfectly on the connection. Suture the incision according to standard clinical procedures. Take a radiograph to verify the proper placement of the implant and attach it to the files.

FRONT

SURGICAL PROTOCOL (step 2)

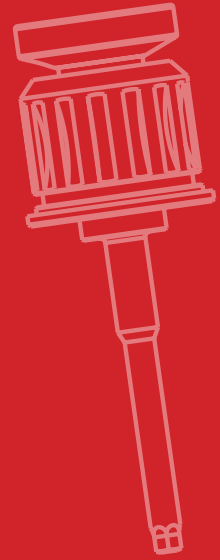
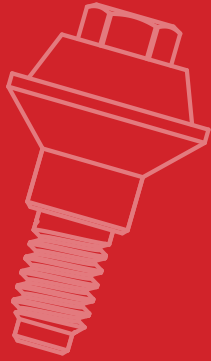

HEALING ABUTMENTS

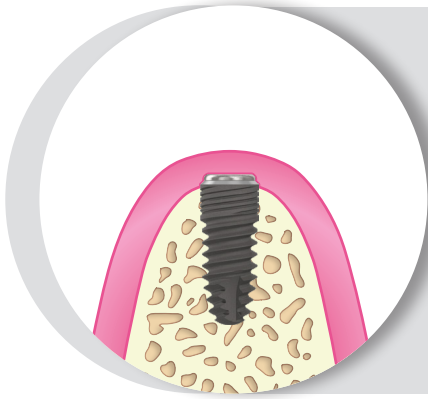

1. Uncover cover screw

Once the implant obtains osseointegration, in the case of a delayed loading protocol, proceed to the second stage of surgery making an incision to uncover cover screw.

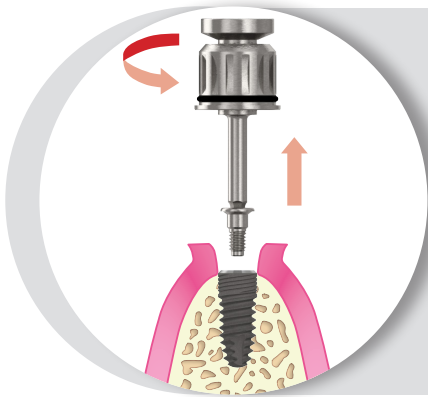

2. Remove the cover screw

Manually unscrew the cover screw from the implant with the HEX-1.20 mm wrench (Ref. KYL0F0128) and extract it from the implant. Ensure that the implant connection is free of bone or soft tissue.

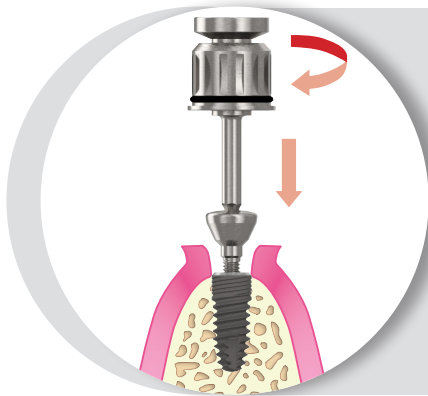

3. Select and thread the healing abutment

Select the height and diameter of the healing abutment according to the emergency profile desired and the thickness of the existing soft tissues. Screw the selected abutment to the implant manually with the HEX-1.20 mm wrench (Ref. KYL0F0128) applying a torque of **15 N·cm**.

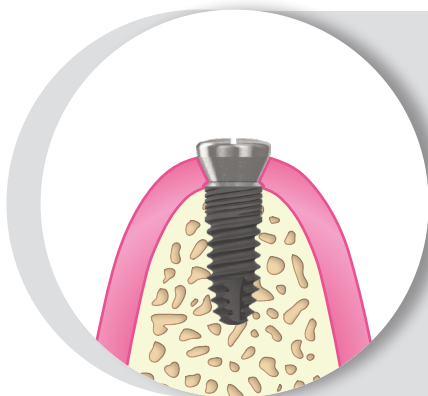

4. Check height and suture

Ensure that the healing abutment is properly placed in the implant, and it stands between 1 and 1.5 mm above the level of the gum. Suture the soft tissue around the abutment and wait until the healing phase has finished.

MULTI-ESTHETIC HEALING ABUTMENTS



▶ FUNCTION

Healing abutments for multi-esthetic abutments are responsible for protecting the parts connecting the abutments and preventing irritation to soft tissues after surgery, when an immediate restoration will not be performed.

▶ NECESSARY MATERIAL

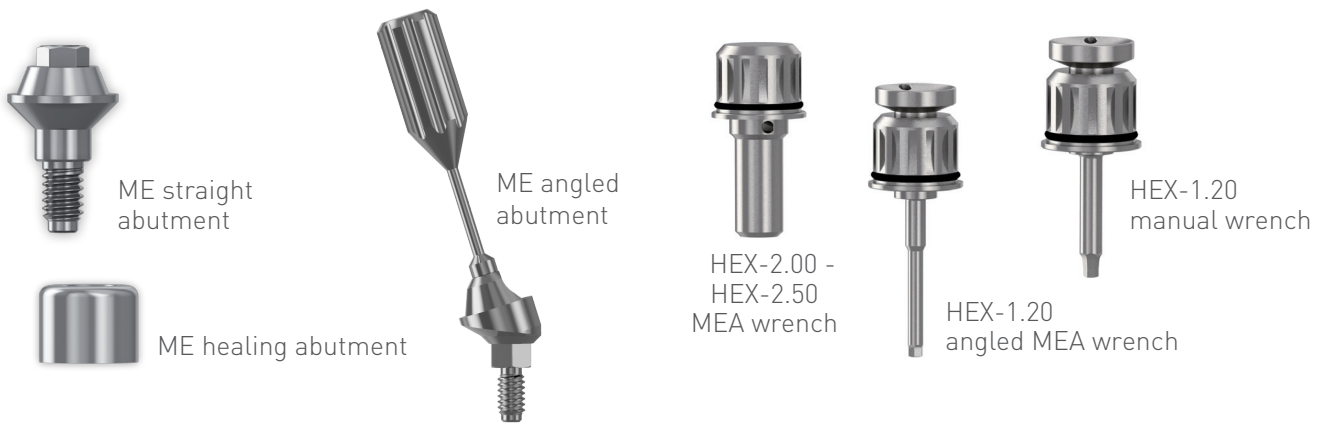

▶ PROCEDURE

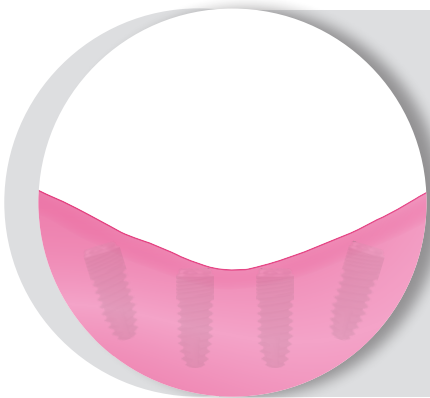

1. Uncover closure caps

Once the implant obtains osseointegration, in the case of a delayed loading protocol, proceed to the second stage of surgery making an incision to uncover the closure caps.

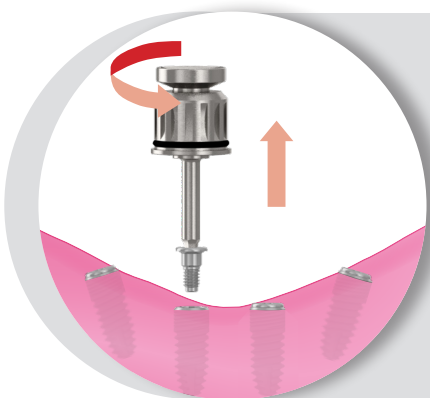

2. Remove the closure caps

Manually unscrew the caps from the implant with the HEX-1.20 mm wrench (Ref. KYL0F0128) and extract them from the implants. Ensure that the implant connections are free of bone or soft tissue.

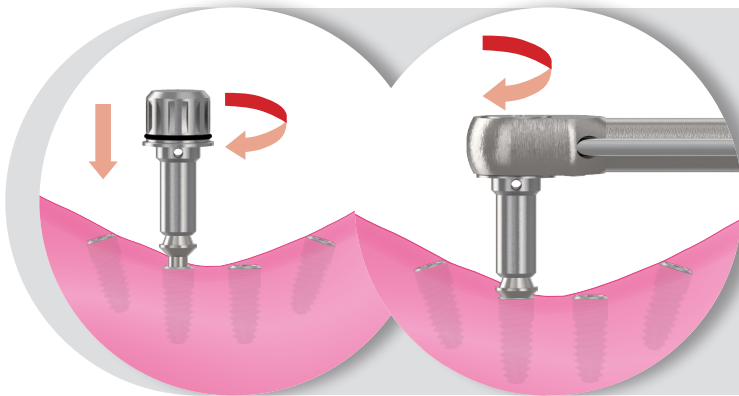

3. Select and thread the ME straight abutments

Select the emergency height and diameter of the ME straight abutments based on the implant platform and the existing soft tissue thickness. Screw the selected abutments to the implants manually with the ME abutment wrench (Ref. KYLOC0149 or KYLOC0098) and end the tightening with the wrench attached to the PI torque wrench using a torque of **30 N•cm**.

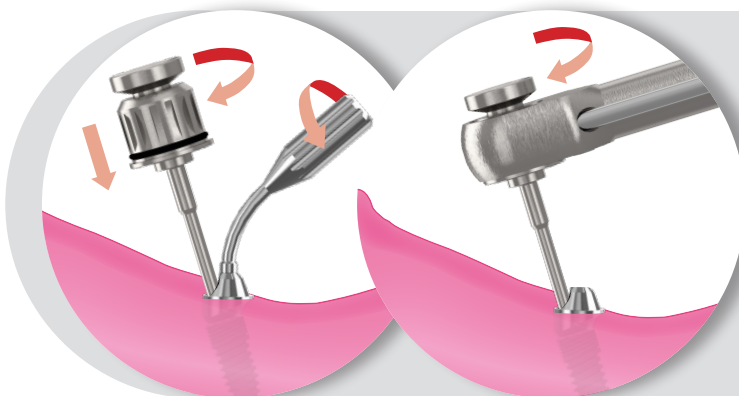

4. Select and thread the ME angled abutments

Select the diameter and angle of the ME abutments depending on the angle of the implant platform. Position the abutment and screw the ME angled abutment to the implant manually with the wrench for the inclined ME abutment (Ref. KYLOF0130). Unscrew the abutment guide and finish the tightening with the wrench attached to the PI torque wrench using a torque of **30 N•cm**.

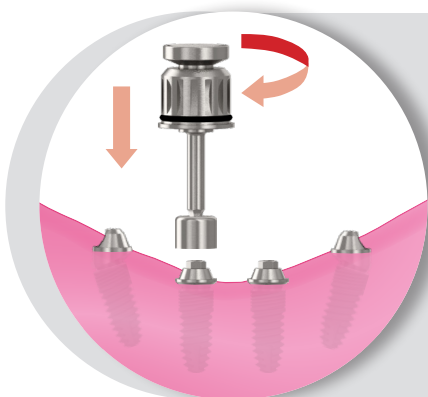

5. Select and thread the ME healing abutments

Ensure that the platform and the cone of the multi-esthetic abutments are free of bone and soft tissue. Select the healing abutment according to the implant platform and screw it to the implant manually with the HEX-1.20 mm wrench (Ref. KYLOF0128) applying a torque of **15 N•cm**.

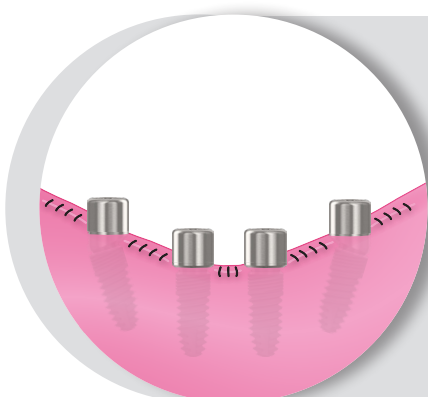

6. Check and suture

Ensure that all the healing abutments are seated correctly. Suture the soft tissue around them.



▶ FUNCTION

Healing abutments for bioesthetic bases are responsible for protecting the parts connecting the BE bases during the soft tissue healing phase, in cases where immediate loading protocol is not performed.

▶ NECESSARY MATERIAL



BE base



Healing abutment BE



BE wrench
HEX-2.00



HEX-1.20
manual wrench

▶ PROCESS

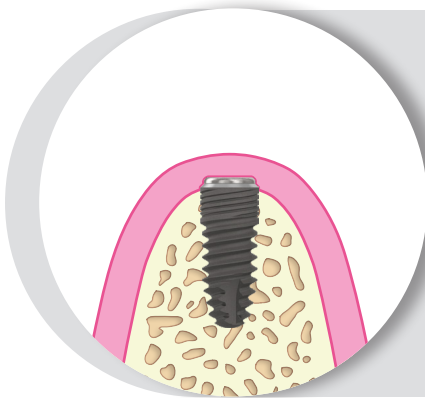

1. Uncover cover screw

Once the implant obtains osseointegration, in the case of a delayed loading protocol, proceed to the second stage of surgery making an incision to uncover cover screw.

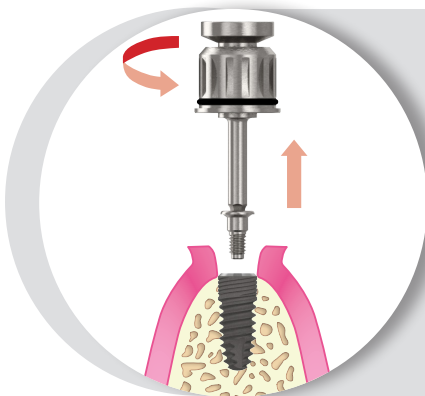

2. Remove the cover screw

Manually unscrew the cover screw from the implant with the HEX-1.20 mm wrench (Ref. KYL0F0128) and extract it from the implant. Ensure that the implant connection is free of bone or soft tissue.

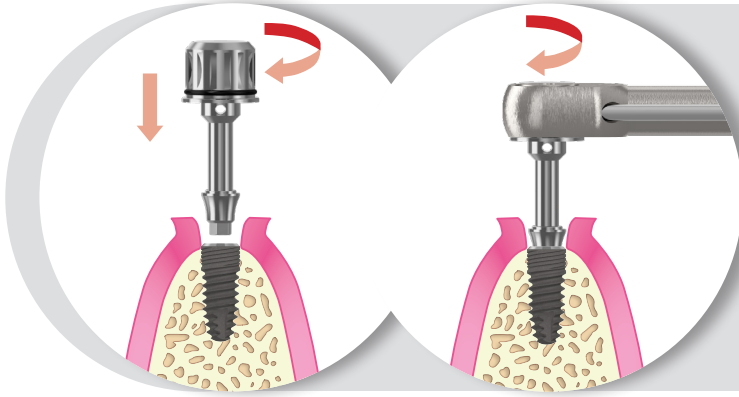

3. Select and place the BE base

Select the emergency height of the BE base based on the implant platform and the existing soft tissue thickness. Place the selected base and fix it to the implant manually with the BE base screw and the BE wrench (Ref. KYLOC0149). End the tightening with the wrench attached to the PI torque wrench using a torque of **25 N•cm**.

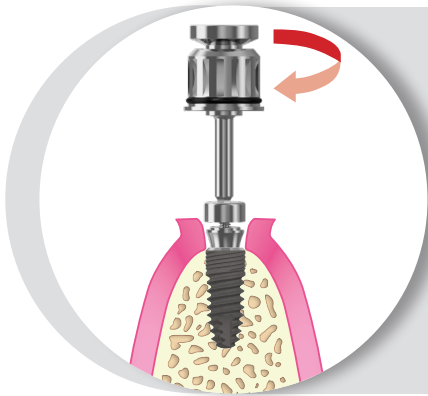

4. Screw the healing abutment

Ensure that the platform and the cone of the bioesthetic base is free of bone and soft tissue.

Screw the healing abutment to the implant manually with the HEX-1.20 mm wrench (Ref. KYLOF0128) applying a torque of **15 N•cm**.

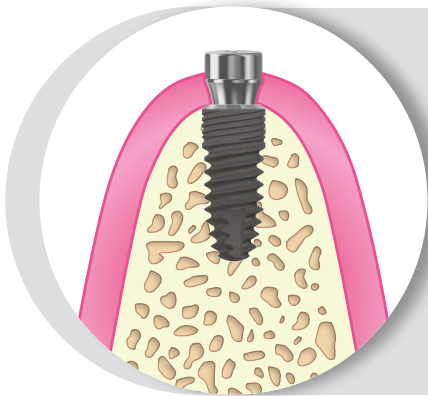

5. Check height and suture

Ensure that the healing abutment is properly placed in the implant, and it stands between 1 and 1.5 mm above the level of the gum.

Suture the soft tissue around the abutment and wait until the healing phase has finished.



 GMI Dental Implantology, S.L.
"Pol. Ind. El Segre" C/ Enginyer Mies 705 B - 25191 Lleida (Spain)
Tel: +34 973 184 350 - info@gmidental.com - www.gmidental.com

