



Guided surgery user manual



www.gmidental.com

ABOUT THIS MANUAL

This user manual of **gmi° guided surgery** is designed exclusively to provide instructions for use for guided surgery procedures of different **gmi°** implant systems, and is not intended to describe diagnosis methods or procedures, treatment planning or the location of the implants, nor does it replace clinical training or clinical judgement about the needs of each patient.

gmi° recommends appropriate and specific training as a prerequisite for the placement of implants and the associated treatment.

The methods illustrated and described in this manual reflect an ideal patient with the bone and soft tissue required for the placement of an implant. We do not intent to cover the wide range of adverse conditions that may negatively affect the success of the surgery or rehabilitation.

The experience and judgement of the clinician in relation to any particular case must always be above the recommendations made in this or any other gmi° manual.



Table of contents

- gmi® guided surgery kits	4
- Kits content	5
- Accessories	11
- Sequence of use	12
- How to select the working sequence according to the diameter of the implant	20
- How to select the drills and how to use them	21
- Specifications	
- Fixing lateral pins	22
- Sleeves for lateral pins	22
- Ferule sleeves	22

gmi® guided surgery kits

gmi® guided surgery kits consist of a sterilizable box by autoclave made of technical plastic, containing all necessary instruments to perform guided surgery procedures:

GMI® FRONTIER GUIDED SURGERY KIT - Ref. KYC0F3047 ●

Totally guided surgeries with gmi® frontier implants of $\varnothing 3.30$ / $\varnothing 3.75$ / $\varnothing 4.25$ and $\varnothing 4.75$ mm and lengths between 8 and 15 mm.



GMI® FRONTIER PEAK GUIDED SURGERY KIT - Ref. KYC0F3048 ●

Totally guided surgeries with gmi® frontier PEAK implants of $\varnothing 3.75$ / $\varnothing 4.25$ and $\varnothing 4.75$ mm and lengths between 8 and 15 mm.

GMI® AVANTGARD GUIDED SURGERY KIT - Ref. KYC0F3049 ●

Totally guided surgeries with gmi® avantgard implants of $\varnothing 3.30$ / $\varnothing 3.75$ / $\varnothing 4.25$ and $\varnothing 4.75$ mm and lengths between 8 and 13 mm.



GMI® AVANTGARD PEAK GUIDED SURGERY KIT - Ref. KYC0F3050 ●

Totally guided surgeries with gmi® avantgard PEAK implants of $\varnothing 3.30$ / $\varnothing 3.75$ / $\varnothing 4.25$ and $\varnothing 4.75$ mm and lengths between 8 and 13 mm.

gmi® guided surgery drill kits

gmi® guided surgery drill kits contain the necessary drills for performing totally guided surgeries with frontier, avantgard and PEAK implants complementing the guided surgery kits.

GMI® FRONTIER/AVANTGARD GUIDED SURGERY DRILL KIT Ref. KYC0F3051 ●●

Totally guided surgeries with **gmi® frontier and avantgard** implants of $\varnothing 3.30$ / $\varnothing 3.75$ / $\varnothing 4.25$ and $\varnothing 4.75$ mm and lengths between 8 and 15 mm.



GMI® PEAK GUIDED SURGERY DRILL KIT - Ref. KYC0F3052 ●●

Totally guided surgeries with **gmi® frontier PEAK and avantgard PEAK** implants of $\varnothing 3.30$ / $\varnothing 3.75$ / $\varnothing 4.25$ and $\varnothing 4.75$ mm and lengths between 8 and 15 mm.

Kit contents - Drill trays

• Pin drill:

It allows to drill the housing of the lateral pins through the sleeves.

Description	Reference	Un.	Kit
Pin drill $\varnothing 1.50$ mm	KYF0C6060	1	●●●●



Kit contents - Drill trays

• Initial drill:

Allows the initial marking of the osteotomy on the bone crest.

Description	Reference	Un.	Kit
Initial drill	KYF0C6101	1	● ● ● ●



• Gingival punch:



Circular scalpel that allows incision in the soft tissue when using the flapless technique.

Description	Reference	Un.	Kit
Gingival punch CA Ø5.10 mm	KYF0C6066	1	● ● ● ●



• Pilot drills:

They allow initial drilling to be carried out to adapt the bone bed to the length of the selected implant.





Description	Color	Reference	Un.	Kit
Pilot drill DLC Ø2.50 L8 mm		KYF0C6201	1	
Pilot drill DLC Ø2.50 L10 mm		KYF0C6202	1	
Pilot drill DLC Ø2.50 L11.5 mm		KYF0C6203	1	● ●
Pilot drill DLC Ø2.50 L13 mm		KYF0C6204	1	
Pilot drill DLC Ø2.50 L15mm		KYF0C6205	1	
Pilot drill DLC Ø2.50 L8 mm		KYF0C6206	1	
Pilot drill DLC Ø2.50 L10 mm		KYF0C6207	1	
Pilot drill DLC Ø2.50 L11.5 mm		KYF0C6208	1	● ●
Pilot drill DLC Ø2.50 L13 mm		KYF0C6209	1	
Pilot drill DLC Ø2.50 L15mm		KYF0C6210	1	



Kit contents - Drill trays

• Step drills:

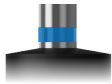
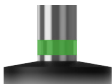
They allow the osteotomy to be widened to adapt it to the diameter of the selected implant.

Description	Color	Reference	Un.	Kit
Step drill DLC $\varnothing 2.5/\varnothing 3$ L8 mm		KYF0C6506	1	
Step drill DLC $\varnothing 2.5/\varnothing 3$ L10 mm		KYF0C6507	1	
Step drill DLC $\varnothing 2.5/\varnothing 3$ L11.5 mm		KYF0C6508	1	
Step drill DLC $\varnothing 2.5/\varnothing 3$ L13 mm		KYF0C6509	1	
Step drill DLC $\varnothing 2.5/\varnothing 3$ L15 mm		KYF0C6510	1	
Step drill DLC $\varnothing 3/\varnothing 3.5$ L8 mm		KYF0C6511	1	
Step drill DLC $\varnothing 3/\varnothing 3.5$ L10 mm		KYF0C6512	1	
Step drill DLC $\varnothing 3/\varnothing 3.5$ L11.5 mm		KYF0C6513	1	
Step drill DLC $\varnothing 3/\varnothing 3.5$ L13 mm		KYF0C6514	1	
Step drill DLC $\varnothing 3/\varnothing 3.5$ L15 mm		KYF0C6515	1	
Step drill DLC $\varnothing 3.5/\varnothing 4$ L8 mm		KYF0C6516	1	
Step drill DLC $\varnothing 3.5/\varnothing 4$ L10 mm		KYF0C6517	1	
Step drill DLC $\varnothing 3.5/\varnothing 4$ L11.5 mm		KYF0C6518	1	
Step drill DLC $\varnothing 3.5/\varnothing 4$ L13 mm		KYF0C6519	1	
Step drill DLC $\varnothing 3.5/\varnothing 4$ L15 mm		KYF0C6520	1	
Step drill DLC $\varnothing 4/\varnothing 4.5$ L8 mm		KYF0C6521	1	
Step drill DLC $\varnothing 4/\varnothing 4.5$ L10 mm		KYF0C6522	1	
Step drill DLC $\varnothing 4/\varnothing 4.5$ L11.5 mm		KYF0C6523	1	
Step drill DLC $\varnothing 4/\varnothing 4.5$ L13 mm		KYF0C6524	1	
Step drill DLC $\varnothing 2.5/\varnothing 2.8$ L8 mm		KYF0C6525	1	
Step drill DLC $\varnothing 2.5/\varnothing 2.8$ L10 mm		KYF0C6526	1	
Step drill DLC $\varnothing 2.5/\varnothing 2.8$ L11.5 mm		KYF0C6527	1	
Step drill DLC $\varnothing 2.5/\varnothing 2.8$ L13 mm		KYF0C6528	1	
Step drill DLC $\varnothing 2.5/\varnothing 2.8$ L15 mm		KYF0C6529	1	



Kit contents - Drill trays

• Conical drills:

They allow the progressive widening of the bone bed, adapting it to the shape of the PEAK implant.

Description		Reference	Un.	Kit
Conical drill DLC Ø3.2 L8 mm		KYF0C6706	1	
Conical drill DLC Ø3.2 L10 mm		KYF0C6707	1	
Conical drill DLC Ø3.2 L11.5 mm		KYF0C6708	1	
Conical drill DLC Ø3.2 L13 mm		KYF0C6709	1	
Conical drill DLC Ø3.2 L15 mm		KYF0C6710	1	
Conical drill DLC Ø3.7 L8 mm		KYF0C6711	1	● ●
Conical drill DLC Ø3.7 L10 mm		KYF0C6712	1	
Conical drill DLC Ø3.7 L11.5 mm		KYF0C6713	1	
Conical drill DLC Ø3.7 L13 mm		KYF0C6714	1	
FConical drill DLC Ø3.7 L15 mm		KYF0C6715	1	
Conical drill DLC Ø4.2 L8 mm		KYF0C6716	1	
Conical drill DLC Ø4.2 L10 mm		KYF0C6717	1	
Conical drill DLC Ø4.2 L11.5 mm		KYF0C6718	1	
Conical drill DLC Ø4.2 L13 mm		KYF0C6719	1	



• Cortical drills:

They allow the cortical part of the osteotomy to be widened to avoid overcompression of the cortex.

Description	Color	Reference	Un.	Kit
Cortical drill DLC Ø3,2 mm		KYF0C6401	1	
Cortical drill DLC Ø3,55 mm		KYF0C6402	1	
Cortical drill DLC Ø3,9 mm		KYF0C6403	1	● ●
Cortical drill DLC Ø4,4 mm		KYF0C6404	1	
Cortical drill DLC Ø4,9 mm		KYF0C6405	1	
Cortical drill DLC Ø3,2 mm		KYF0C6406	1	
Cortical drill DLC Ø3,65 mm		KYF0C6407	1	● ●
Cortical drill DLC Ø4,15 mm		KYF0C6408	1	
Cortical drill DLC Ø4,65 mm		KYF0C6409	1	



Kit contents - Instrument trays

• Mounter extraction wrench:

It allows to disassemble the carrier from the ferule sleeve manually or using the TI ratchet wrench.

Description	Reference	Un.	Kit
Mounter extraction wrench	KYLOC6115	1	● ● ● ●



• Screwdriver:

Hexagonal tip of HEX-1.20 mm that allows to tighten / loosen the mounter screws.

Description	Reference	Un.	Kit
Short ratchet wrench HEX-1.20 mm	KYLOF0128	1	● ● ● ●



• Adapters:

Once coupled to the carrier they allow the tightening of the implant.

Description	Reference	Un.	Kit
Adapter Hex-4.00 mm TIRW	KYLOC6054	1	● ● ● ●
Adapter Hex-4.00 mm HP	KYLOC6055	1	



• Implant carriers:

They allow to remove the implant from the container and place it in the ferule sleeve in a guided way until its final position by screw fixing.

Description	Reference	Un.	kit
Implant carriers RP/WP + screw	KYLOF6103	4	● ●
Implant carriers NP/RP + screw	KYLOF6107	2	● ●
Implant carriers WP + screw	KYLOF6108	2	

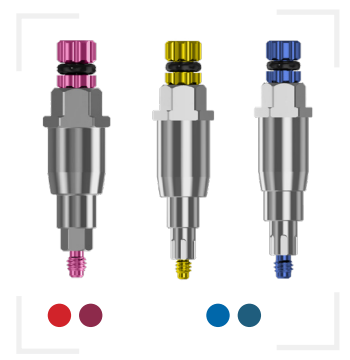

Kit contents - Instrument trays

• Direct insertion wrenches:

They allow to remove the implant from the container and place it in the ferule sleeve in a guided way until its final position by direct insertion.

Description	Reference	Un.	kit
frontier direct HP wrench RP/WP	KYLOF6105	1	● ●
frontier direct TIRW wrench RP/WP	KYLOF6106	1	
avantgard direct HP wrench NP/RP	KYLOF6111	1	
avantgard direct HP wrench WP	KYLOF6112	1	● ●
avantgard direct TIRW wrench NP/RP	KYLOF6113	1	
avantgard direct TIRW wrench WP	KYLOF6114	1	

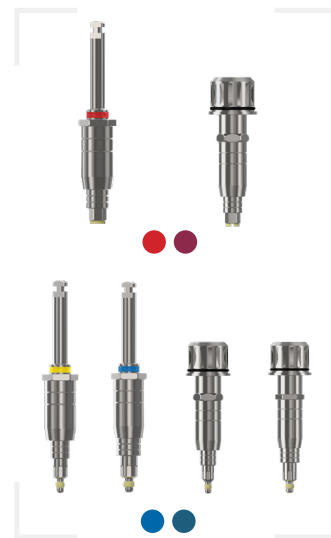

• Lateral pins:

Elements that allow to fix temporarily the ferule in patient's mouth by anchoring in the tissues.

Description	Reference	Un.	Kit
Lateral pin	KYLOC6059	3	● ● ● ●



• TI ratchet wrench:

Once coupled to the wrench it allows to insert the implant at the recommended torque.

Description	Reference	Un.	Kit
TI ratchet wrench	KYLOF0113	1	● ● ● ●



• Implant carrier manual wrench:

Once coupled to the external hexagon of the carrier it enables avoiding the rotation of the implant when the clinical screw is loosened

Description	Reference	Un.	Kit
45° implant carrier manual wrench	KYLOC0093	1	● ● ● ●



Accessories

• Drilling guide sleeves:

Once fixed to the surgical drilling guide, they allow to guide the drilling sequence and the placement of the implant in the planned position.

Description	Reference	Un.
Sleeve ø5.10 mm	KYL0F6102	5



• Sleeves for lateral pins:

Cylindrical pieces that are incorporated to the ferule to allow the placement of the lateral pins.

Description	Reference	Un.
Sleeve for lateral pin	KYL0F6061	5



Sequence of use



1

Get the morphology of the jaws of the patient to be treated through TAC and export it in DICOM format.

1 Carga de datos

Cargar carpeta con imagenes DICOM (DCM) presionando el boton Cargar DICOM. Cargar modelo STL escaneado presionando boton Cargar STL.

Cargar DICOM

Recortar

Cargar STL

2

Import DICOM file into the implant planning software.

1 Carga de datos

Cargar carpeta con imagenes DICOM (DCM) presionando el boton Cargar DICOM. Cargar modelo STL escaneado presionando boton Cargar STL.

Cargar DICOM

Recortar

Cargar STL

3

Import STL from intraoral scanner.

Frontier implant RP Ø3,30 L8 mm

11 Right maxilar central incisor

Implante seleccionado:

GMI - Frontier | Frontier implant RP Ø3,30 L8 mm - Ningun pilar seleccionado

4

Plan de case by selecting the diameters and lengths of the **gmi** implants, as well as their insertion axis and the desired depth.

Sequence of use

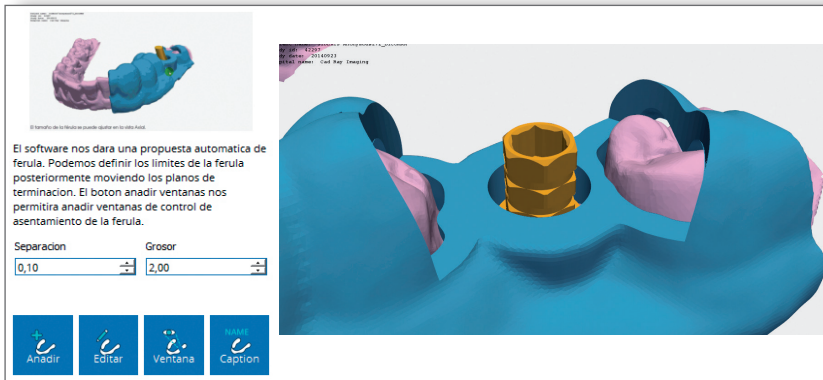

5 *Design the morphology of the surgical drilling guide, the housing of the drilling guide sleeves and the position of the lateral pins according to the planning.*

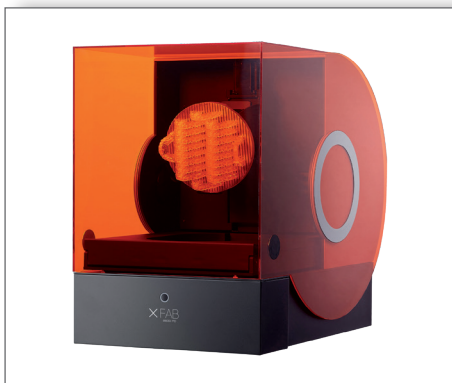

6 *Print the surgical drilling guide by 3D printing.*

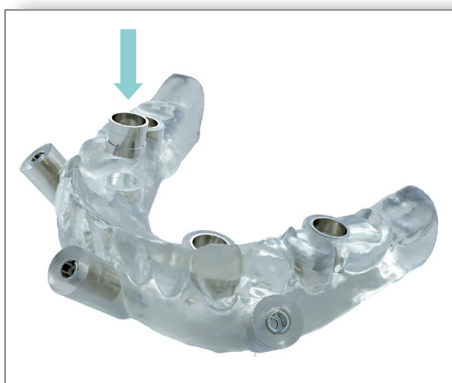

7 *Place and fix the drilling guide sleeves and the sleeves for lateral pins in the corresponding holders.*

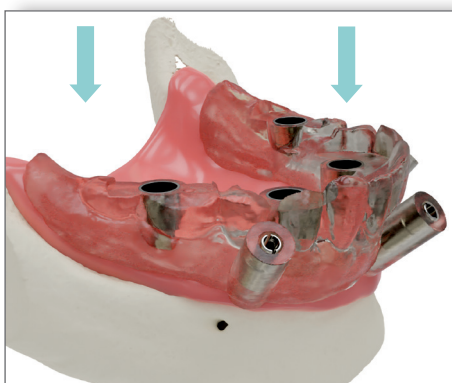

8 *Place the drilling guide in the patient's mouth and check it seats correctly.*

Sequence of use



9

Drill on the bone the housing of the lateral pins with the drill of $\varnothing 1.50$ mm and fix the drilling guide.



10

For flapless surgery use the gingival punch to make a circular incision.

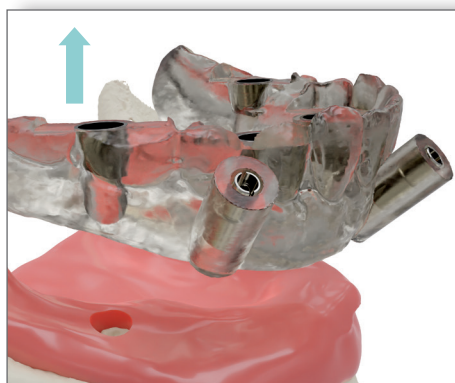

11

Remove the drilling guide and the soft tissue cut with the gingival punch, with a suitable instrument.



12

Re-fix the drilling guide to the patient by the lateral pins.

Sequence of use

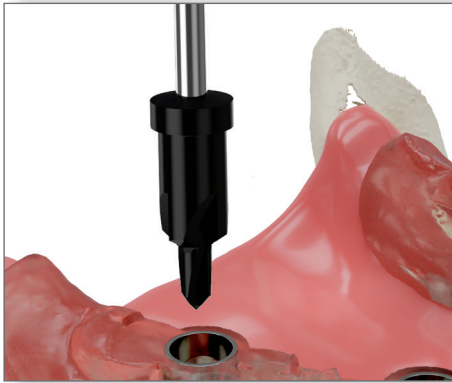

13

Use the lance-shaped drill to start the osteotomy and plan the crest to achieve a correct seating of the guide sleeve.

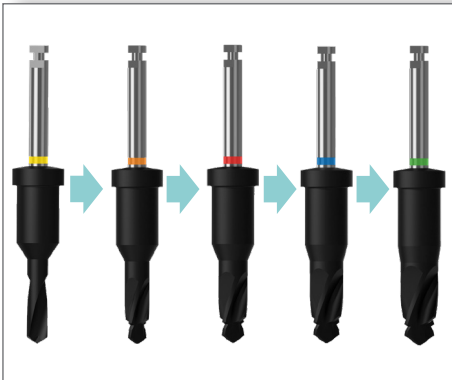

14

Select the suitable drilling sequence according to the type of bone, diameter and length of the implant to be placed*. Use plenty of external cooling with saline solution at a low temperature, during all the drilling process.

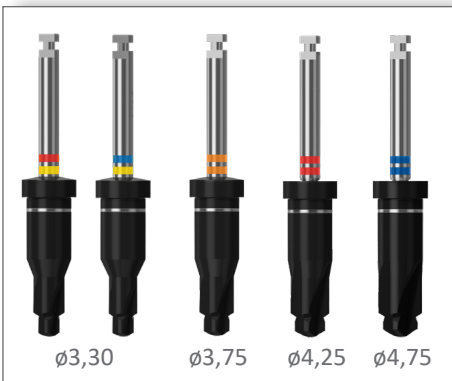

15

Select the suitable cortical drill for the implant to be placed*.



16

Open the secondary and primary packaging of the implant.

*See the selection table on page 20

Sequence of use - Direct insertion (Option A)



17

Select the suitable wrench for the implant platform, face the hexagon (frontier) or the grooves (avantgard) of the wrench to the implant and insert it totally.



18

Gently remove the wrench-implant assembly from the packaging.

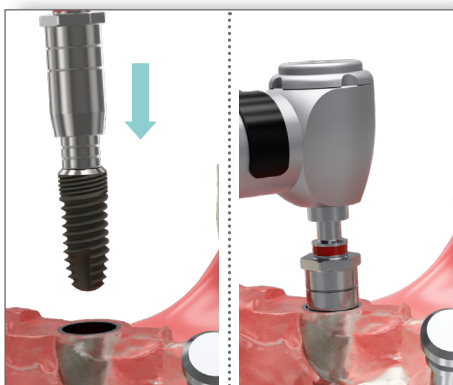

19

Insert the assembly in the sleeve of the surgical guide and make the initial threading in the bone bed.

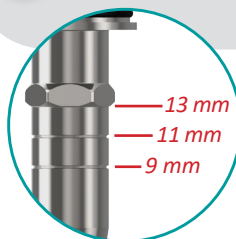

20

Use the HEX-4.0 adapter coupled to the TI ratchet wrench to make the final threading of the implant until it stops with the drilling guide sleeve without exceeding the recommended tightening torque.

Sequence of use - Direct insertion (Option A)

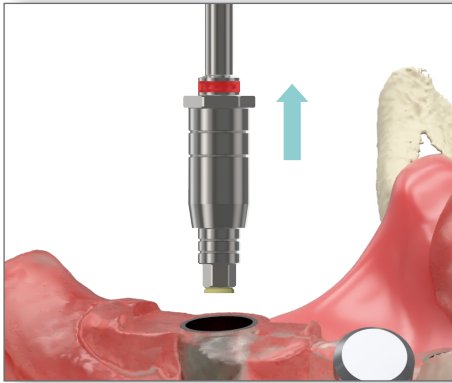

21

Remove the wrench and repeat the process for each implant to be placed.

Sequence of use - Insertion with carrier (Option B)

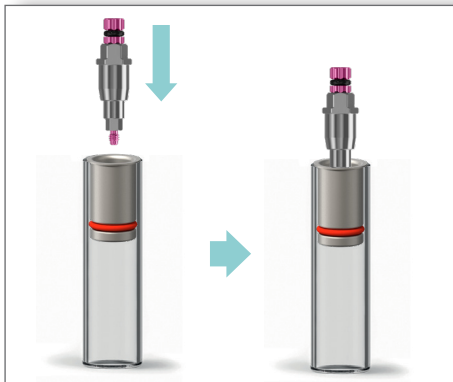

17

Select the suitable carrier for the implant platform, face the mounter to the implant and insert it totally.



18

Thread the screw of the carrier to the implant manually or using the screwdriver.

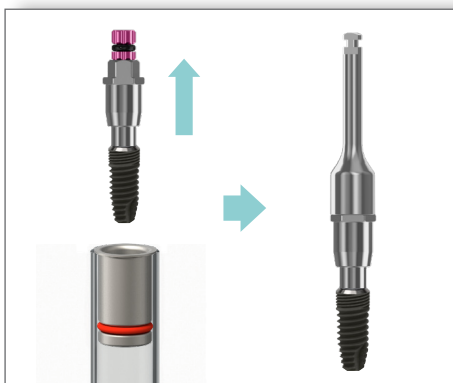

19

Gently remove the carrier-implant assembly from the packaging either manually or by using the adapter.

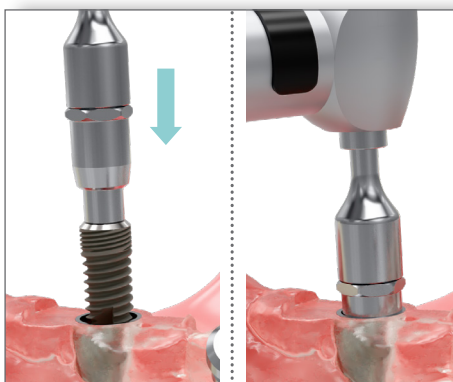

20

Insert the assembly in the sleeve of the surgical guide and make the initial threading in the bone bed.

Sequence of use - Insertion with carrier (Option B)



21

Use the the HEX-4.0 adapter coupled to the TI ratchet wrench to make the final threading of the implant until it stops with the drilling guide sleeve without exceeding the recommended tightening torque.

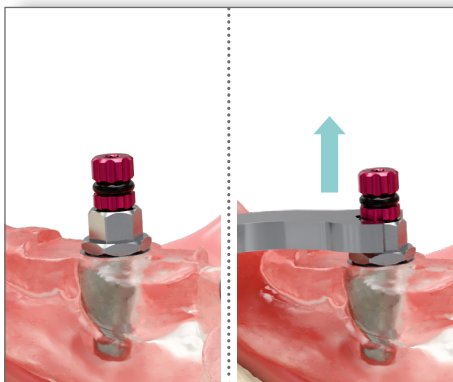

22

Hold the carrier with the flat wrench and remove the carrier screw.

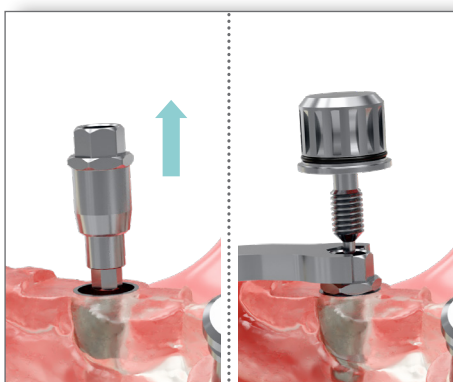

23

Remove the carrier from the implant. If it cannot be easily removed, use the extractor for ratchet.

24

Repeat the process for each implant to be placed.

How to select the working sequence according to the diameter of the implant

• gmi® frontier - avantgard implants:

∅ Implant (mm)	Implant platform	Recommended work sequence
● ∅3.30	NP	Punch ∅5.1 - Initial - Drill ∅2.5 - (∅3.0)* - Cortical AV ∅3.30
	RP	Punch ∅5.1 - Initial - Drill ∅2.5 - (∅3.0)* - Cortical FR ∅3.30
● ∅3.75	RP	Punch ∅5.1 - Initial - Drill ∅2.5 - ∅3.0 - (∅3.5)* - Cortical ∅3.75
● ∅4.25		Punch ∅5.1 - Initial - Drill ∅2.5 - ∅3.0 - ∅3.5 - (∅4.0)* - Cortical ∅4.25
● ∅4.75	WP	Punch ∅5.1 - Initial - Drill ∅2.5 - ∅3.0 - ∅3.5 - ∅4.0 - (∅4.5)* - Cortical ∅4.75

* Optional for hard bones type I/II.

• Implantes gmi® frontier PEAK - avantgard PEAK:

∅ Implant (mm)	Implant platform	Recommended work sequence
● ∅3.30	NP	Punch ∅5.1 - Initial - Drill ∅2.5 - ∅2.8 - Cortical ∅3.30
● ∅3.75	RP	Punch ∅5.1 - Initial - Drill ∅2.5 - ∅2.8 - ∅3.2 - Cortical ∅3.75
● ∅4.25		Punch ∅5.1 - Initial - Drill ∅2.5 - ∅2.8 - ∅3.2 - ∅3.7 - Cortical ∅4.25
● ∅4.75	WP	Punch ∅5.1 - Initial - Drill ∅2.5 - ∅2.8 - ∅3.2 - ∅3.7 - ∅4.2 - Cortical ∅4.75

How to select the drills and how to use them



1- Select according to the drilling sequence and length.



2- Check that the selected drill corresponds to the required length and diameter.



3- Insert the first drill into the surgical drilling guide sleeve until it stops.



4- Remove the drill and store it in its place in the kit.



5- Go on with the drilling sequence.

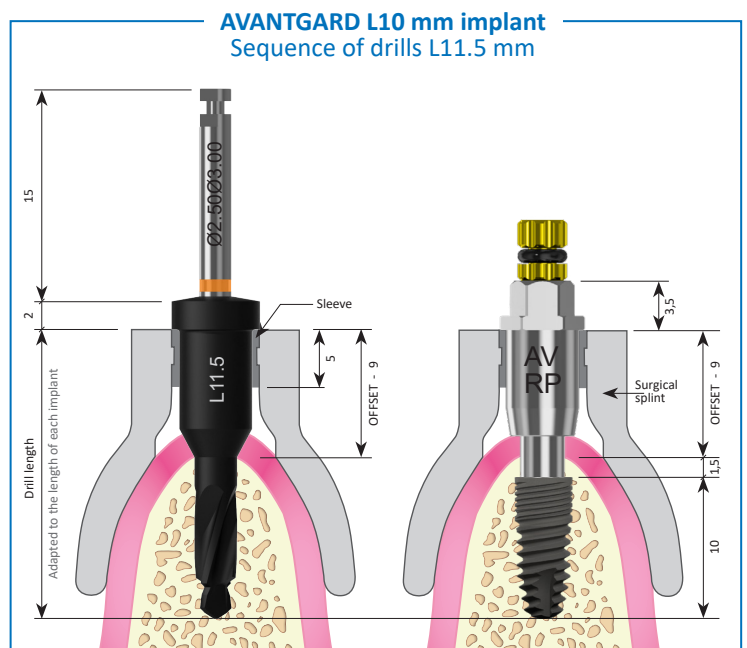
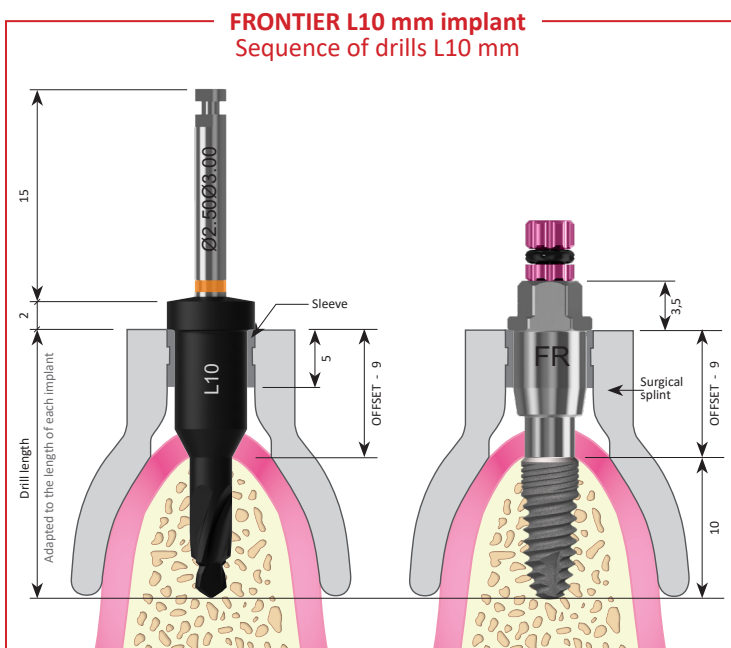

Specifications

- Fixing lateral pins:

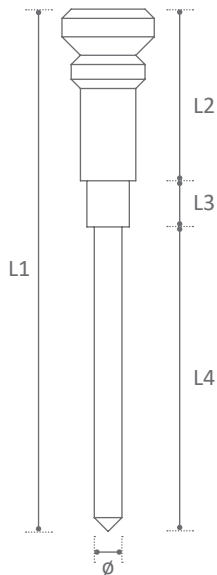

Reference	L1	L2	L3	L4	Ø
KYL0C6059	28.30 mm	9.30 mm	2.50 mm	16.50 mm	1.50 mm

- Sleeves for lateral pins:

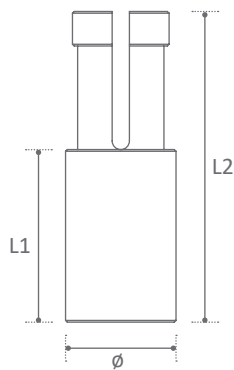

Reference	L1	L2	Ø
KYL0F6061	5.00 mm	9.00 mm	3.20 mm

- Drilling guide sleeves:

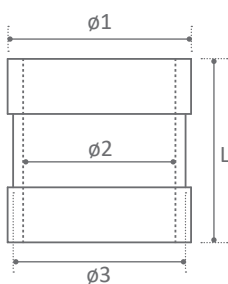

Reference	L	Ø1	Ø2	Ø3
KYL0F6102	5.00 mm	5.90 mm	5.10 mm	5.60 mm

 **GMI**
Dental Implantology, S.L.

Pol. Ind. El Segre
C/ Enginyer Mies 705-B
25191 Lleida (SPAIN)
Tel. (+34) 973 184 350
info@gmidental.com
www.gmidental.com



Distributed by:

